

IM1955

***Turbo VM 1600***  
***Turbo VM 2000***

**OPERATING INSTRUCTIONS  
AND  
PARTS LISTING**

ISSUE 1

**IMPORTANT**

NOTE HERE THE SERIAL NUMBER OF YOUR MACHINE AND ALWAYS QUOTE IT IN ANY COMMUNICATION WITH US OR YOUR DEALER. THIS IS PARTICULARLY IMPORTANT WHEN ORDERING SPARES. REMEMBER TO INCLUDE ALL NUMBERS AND LETTERS.

MACHINE SERIAL NUMBERS \_\_\_\_\_

THE INFORMATION GIVEN THROUGHOUT THIS MANUAL IS CORRECT AT THE TIME OF PUBLICATION. HOWEVER, IN THE COURSE OF CONSTANT DEVELOPMENT OF BOMFORD TURNER MACHINES, CHANGES IN SPECIFICATION ARE INEVITABLE. SHOULD YOU FIND THE INFORMATION GIVEN IN THIS BOOK TO BE AT VARIANCE WITH THE MACHINE IN YOUR POSSESSION, YOU ARE ADVISED TO CONTACT THE BOMFORD TURNER SERVICE DEPARTMENT WHERE UP-TO-DATE INFORMATION WILL BE PROVIDED.

THE MANUAL CAN CONTAIN STANDARD AND OPTIONAL FEATURES AND IS NOT TO BE USED AS A MACHINE SPECIFICATION.

THE MACHINE HAS BEEN TESTED AND IS CONSIDERED SAFE IF CAREFULLY USED. ENSURE YOUR OPERATOR IS PROPERLY TRAINED IN ITS USE AND MAINTENANCE.

---

**IMPORTANT**

NOTEZ ICI LES NUMEROS DE SERIE DE VOTRE MACHINE ET MENTIONNEZ LES DANS TOUTE COMMUNICATION AVEC NOS SERVICES OU VOTRE REVENDEUR. CECI EST IMPORTANT POUR LA COMMANDE DE PIECES DETACHEES. PENSEZ A NOTER TOUS LES NUMEROS ET TOUTES LES LETTERS.

NUMEROS DE SERIE DE LA MACHINE \_\_\_\_\_

LES INFORMATIONS DONNEES DANS CE MANUEL SONT CORRECTES CEPENDANT, DU FAIT DE DEVELOPPEMENT CONSTANT DES MACHINES BOMFORD TURNER.

CHANGEMENTS DANS LES CARACTERISTIQUES SONT INEVITABLES.

SI VOUS TROUVEZ QUE LES INFORMATIONS DONNEES NE CORRESPONDENT PAS A VOTRE MACHINE VEUILLEZ CONTACTER LE SERVICE DES REPARATIONS OU DES INFORMATIONS PLUS RECENTES VOUS SERONT DONNEES.

CE MANUEL PEUT MONTRER DES CARACTERISTIQUES OPTIONNELLES ET NE PEUT PAS ETRE CONSIDERE COMME SPECIFICATION DE LA MACHINE.

CETTE MACHINE A ETE TESTEE, ET ELLE EST CONSIDEREE COMME FIABLE A CONDITION D'UNE BONNE UTILISATION. ASSUREZ-VOUS QUE VOTRE OPERATEUR EST QUALIFIE EN CE QUI CONCERNE L'UTILISATION DE LA MACHINE AINSI QUE SON ENTRETIEN.

---

**WICHTIG**

TRAGEN SIE HIER DIE SERIENNUMMERN IHRER MASCHINE EIN UND GEBEN SIE DIESE IMMER AN, WENN SIE SICH AN UNS ODER IHREN HÄNDLER WENDEN. DAS IST BESONDERS BEI ERSATZTEILBESTELLUNGEN WICHTIG. VERGESSEN SIE NICHT, ALLE ZAHLEN UND BUCHSTABEN ZU NOTIEREN.

SERIENNUMMERN DER MASCHINE \_\_\_\_\_

DIE ANGABEN IN DIESEM HANDBUCH SIND BEI VERÖFFENTLICHUNG KORREKT. AUFGRUND DER KONSTANTEN WEITERENTWICKLUNG VON BOMFORD TURNER MASCHINEN SIND JEDOCHÄNDERUGDEN IN DER SPEZIFIKATION UNVERMEIDLICH. WENN DIE INFORMATION IN DIESEM HANDBUCH NICHT MIT IHRER MASCHINE ÜBEREINSTIMMEN, NEHMEN SIE BITTE KONTAKT MIT DER BOMFORD TURNER KUNDENDIENSTABTEILUNG AUF, DIE IHNEN GERNE DIE AKTUELLEN INFORMATION ZUKOMMEN LÄSST.

DAS HANDBUCH KANN SOWOHL BESCHREIBUNGEN FÜR DIE STANDARD AUSFÜHRUNG ALS AUCH FÜR ZUBEHÖR ENTHALTEN UND IST NICHT ALS MASCHINENSPEZIFIKATION ZU VERWENDET.

DIE MASCHINE IST GETESTET UND BEI SACHGEMÄSSEM BETRIEB ALS SICHER BEFUNDEN WORDEN. SORGEN SIE DAFÜR, DASS IHR BEDIENPERSONAL IN ANWENDUNG UND WARTUNG RICHTIG GESCHULT WIRD.

**CONTENTS**

<b>1 GENERAL INFORMATION</b>	
1.1. Introduction	6
1.2. Identifying the machine	6
1.3. Spare parts	6
<b>2 TECHNICAL DATA</b>	
2.1. Specification	7
2.2. Description	7
2.3. General Arrangement	8
<b>3 SAFETY</b>	
3.1. Safety Information	9
3.2. Emergency Stop	10
3.3. Noise	10
3.4. Safety Decals	10
<b>4 INSTALLATION</b>	
4.1. Tractor Requirements	12
4.2. Hydraulic Requirements	12
4.3. Machine Preparation	12
4.4. To Move Machine from Delivery to Work Position	13
4.5. Fitting Machine to Tractor	13
4.6. Fitting the PTO Shaft	14
4.7. Connecting the Hydraulic Control System	14
<b>5 GUARDS</b>	
5.1. Safety Guarding	14
5.2. Inspection of Guards	14
<b>6 OPERATION</b>	
6.1. Initial Checks	15
6.2. Normal Pre-start Checks	15
6.3. Initial Run Up	15
6.4. Normal Run Up	15
6.5. Stalling the Rotor	15
6.6. Safety Break Back	16
6.7. Roller Height	16
6.8. Transporting To and From Work	16
6.9. Storage	17
6.10. Parking and Removal	17
<b>7 MACHINE MAINTENANCE</b>	
7.1. Roller Height Adjustment	18
7.2. Hydraulic Hoses	18
7.3. Fitting Replacement hydraulic Hoses	18
7.4. PTO and Intermediate Shaft	19
7.5. Lubrication	19
7.6. To Grease Rotor Shaft Bearings	20
7.7. Gearbox Lubrication	20
7.8. Drive Belts	20
7.9. Rotor Shaft	21
7.10. General	22
7.11. Fitting Mulch Bar Kit	22

**CONTENTS (Continued)****8 REPLACEMENT PARTS**

Mainframe & Links	24
Arm Assembly	26
Cutting Head 1600	28
Cutting Head 2000	30
Roller Assemblies	32
Ram Assemblies	34
Hoses	36
PTO, Intermediate Shaft and Gearboxes	38
Rotor Drive and Bearings	40
Rotor Shafts	42
Decals	44

**LIST OF ILLUSTRATIONS****Figure.**

1.	Serial Record Plate	6
2.	General Arrangement	8
3.	Safety Decals	11
4.	Machine in Shipping Position	12
5.	Attachment to Tractor	13
6.	Fitting PTO Shaft	14
7.	Transport	16
8.	Hoses	19
9.	Greasing Decal	20
10.	Drive Belts	20
11.	Drive Belt Adjustment	21
12.	Mulch Bar Position	22

EC DECLARATION OF CONFORMITY  
conforming to EEC Directive 98/37/EC

We,

of BOMFORD TURNER LIMITED, Station Road, Salford Priors, Evesham,  
Worcestershire, WR11 5SW

declare that under our sole responsibility that the product (type)

Turbo VM1600, Turbo VM2000

Product Code: VM16, VM20

Serial No. & Date: .....

Manufactured by the above Company/\* .....

.....

(\*insert business name and full address if not stated above)

complies with the required provisions of the Directive 98/37/EC and 89/336/EEC,  
AMD 92/31/EEC, AMD 93/68/EEC and conforms with European Norm. BS EN 292

Part 1: 1991 Safety of Machinery - Terminology, Methodology  
Part 2: 1991 Safety of Machinery - Technical Specifications

and other national standards associated with its design and construction as listed in the Technical File.

Signed .....  
on behalf of BOMFORD TURNER LIMITED Responsible Person

Status      Engineering Manager

Date      21/02/06

## 1. GENERAL INFORMATION

### 1.1 Introduction

This manual describes the Turbo VM range of flail mowers designed for cutting roadside verges and similar areas. The machines are available in 1.6 and 2.0 meter widths and are attached to the tractors 3 point linkage system. They are driven from the tractors PTO output and the cutting head folds vertically for ease of transport. This manual should be read in conjunction with the tractor operator's manual. It is essential that these Manuals are read and fully understood before operating the machine. It is important that the machine be operated in line with the procedures and practices detailed in this manual.

### 1.2 Identification

Each mower is fitted with an identification plate; both the data necessary to identify the model and the serial number to order spare parts or after-sales service are stamped on the plate (see Fig.1).

Fig.1

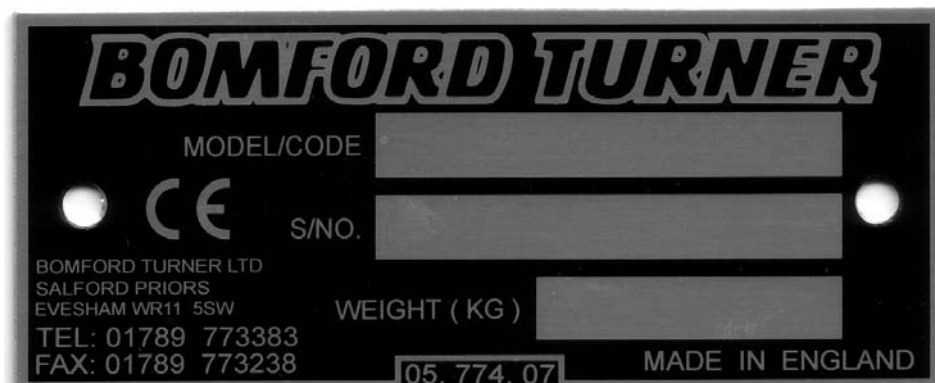

### 1.3. Spare Parts

It is strongly recommended to use genuine Bomford spare parts to avoid altering the technical features of the mower. Bomford Turner Ltd is not responsible for any damage or injuries to people due to unauthorized modifications or to the use of non-genuine spare parts.

## 2. TECHNICAL DATA

### 2.1 Specification

<b>Machine details</b>	<b>Turbo VM1600</b>	<b>Turbo VM2000</b>
Tractor Requirements	60HP	80HP
Maximum offset	750mm	750mm
Transport width	Within tractor	Within tractor
Machine weight (complete)	1180kg	1240kg
<b>Cutting Head</b>		
Cutting width	1600mm	2000mm
Cowl angle movement (+90° to -50°)	140°	140°
Rotor shaft speed @ 1000 rev/min PTO	2250 rev/min	2250 rev/min
Number of Flails	44	54
<b>Options</b>		
	Mulch Bar	Mulch Bar

### 2.2. Description

A rigid box section mainframe has attachment points for coupling the machine to the tractor's 3 point linkage mounting system and pivot points for the two links connecting the arm of the machine to the mainframe. The links permit offset of the machine and one link features a spring loaded break-back mechanism to limit damage should the cutting head strike an obstacle.

The cutting head; housing the rotor shaft and flails, is attached to the end of the arm and is pivoted to enable it to follow ground contours and to be raised for transport purposes.

A hydraulic ram connecting the arm to one of the links permits on the move adjustment of the cutting heads offset. A second ram between the arm and head permits movement of the head from transport to work and an accumulator in the hydraulic circuit permits the cutting head to float over ground contours. Hydraulic power is provided by the tractor spool valve,

The rotor shaft is driven from the PTO output of the tractor; a PTO shaft connects from the tractor to a 90° bevel gearbox positioned on the arm and an intermediate shaft connects between the gearbox and second swivel gearbox on the cutting head. This gearbox and the rotor shaft are connected by pulleys and belts to drive the rotor shaft. The belts are adjustable for tension,

The rotor shaft revolves in 45mm diameter spherical roller bearings. The bearings may be greased and are fitted with seals to prevent the ingress of dirt and moisture.

A 150 mm diameter roller is fitted and is adjustable for height – the position of the roller setting the cutting height of the machine. Sturdy rubber guards are fitted front and rear to protect from objects being thrown from the machine.

A mulch bar kit is available as an option. This is designed to permit additional shredding of the cut material.

**2.3. General Arrangement**

**Fig.2**



### 3. SAFETY

#### 3.1 Safety Information

Read, Understand and Follow the Safety Messages. Serious injury or death may occur unless care is taken to follow the warnings and instructions given in the safety messages,

**CAUTION!** The lowest level of Safety Message; warns of possible injury.

**WARNING!** Serious injury or possible death.

**DANGER!** Imminent death/critical injury.

Never operate the tractor or machinery until you have read and completely understand this manual and the tractor operator's manual and each of the safety messages found in the manuals and those displayed on the tractor and implement.

**DANGER!** DO NOT attempt any maintenance of or adjustment to the machine while it is running. Before carrying out any work on the machine follow the three safety instructions below:

- a LOWER THE MACHINE ON TO THE GROUND
- b PUT THE PTO OUT OF GEAR
- c STOP THE TRACTOR ENGINE AND APPLY BRAKES

**WARNING!** The operator and all support personnel must wear the appropriate safety clothing i.e. safety glasses and protective footwear at all times for protection from injury by objects thrown from the machine.

**DANGER!** Never allow passengers especially children to ride on the tractor or implement. Falling off can kill.

**DANGER!** At all times ensure that the PTO shaft guard is in position, securely fitted and in good condition and that the tractor PTO shaft shield is fitted.

**CAUTION!** Replace the PTO shaft guard if any of the following are evident:- guard cracked or damaged any part of the PTO shaft exposed. Ensure the PTO shaft guard is free to rotate and the anti-rotation chains are securely fitted and effective.

**WARNING!** Ensure that the correct guards are properly fitted to the machine and tractor at all times and check that they are in good condition. Ensure you have the correct guards fitted for the type of operation being performed. Missing or damaged guards must be replaced immediately. The roller is an essential part of the machine guarding. The machine must not be used with the roller removed or missing.

**WARNING!** While the tractor is running all personnel should keep well clear of the area around the machine as there are numerous crushing, shearing, impact dangers caused by the machine operation.

**DANGER!** **AVOID WIRE.** It can be extremely dangerous if wire catches in the flails of the machine, and every care must be taken to ensure this will not happen. Inspect the working area before commencing. Remove all loose wire and obstructions and clearly mark those that are fixed so that you can avoid them. Any unusual noise from the cutting unit area indicates that the flails and shaft may have been fouled by an obstruction. A visual indication that wire has become entangled may be a sudden movement of the vegetation ahead of the machine. In any such event STOP the tractor engine INSTANTLY. On no account move the machine until shaft has completely stopped. When the machine has stopped check it and remove any obstruction that may be present. If working under a raised machine ensure that it is safely supported.

**WARNING!** Before working on the machine always stop the tractor engine and remove the ignition key.

- DANGER!** These machines are capable under adverse conditions of throwing objects great distances at high velocity. CHECK the flails for wear and the attachment bolts for tightness every day during work .A few moments whenever the machine is stopped, e.g. whenever removing obstructions, will help reduce flail wear or loss.
- DANGER!** Keep your forward speed to a level appropriate to the operating conditions. High-speed manoeuvres are very dangerous, particularly on uneven ground where there is risk of overturning.
- DANGER!** Keep a careful watch for passers by who may inadvertently get in the way of cut material being thrown from the machine. These machines are capable under adverse conditions of throwing objects great distances at high velocity. Stop the machine until all people are well clear.
- WARNING!** Extreme care should be taken when operating near loose objects such as gravel, rocks, wire, and other debris. Inspect the area before mowing. Foreign objects should be removed from the site to prevent machine damage and/or bodily injury or even death. Any objects that cannot be removed must be clearly marked and carefully avoided by the operator. Stop mowing immediately if flails strike a foreign object. Repair all damage and make certain the flails and shaft are still balanced before resuming cutting operations.
- WARNING!** Transport the machine only at safe speeds. Serious accidents and injuries can result from operating this equipment at unsafe speeds
- DANGER!** Never transport the machine or attempt maintenance with the shaft running. Serious injury or even death can result from contact with rotating parts
- WARNING!** Ensure the shaft has stopped rotating after the PTO is disengaged before attempting maintenance or adjustment. The shaft may continue to rotate for some time after the tractor PTO has stopped.
- DANGER!** Never leave the machine in the raised transport position. The machine could fall inadvertently and cause injury or death to anyone who might be under the machine.
- DANGER!** Never work under a raised machine unless it has been securely supported and blocked using suitable supports. Sudden or inadvertent falling of the machine could cause injury or even death

### 3.2 Emergency Stop

To stop the machine in an emergency use the tractor stop control. This must only be done in an emergency as its use to stop the machine can cause damage. After an emergency stop of the machine; ensure that the PTO is disengaged before restarting the tractor.

### 3.3 Noise

The equivalent daily personal noise exposure from this machine, measured at the operator's ear, is within the range 80-85dB when used in conditions where the load fluctuates between zero and maximum.

This applies when the machine is attached to a tractor fitted with a quiet cab and used in accordance with the operating instructions in a generally open environment.

At equivalent daily noise exposure levels of between 85 and 90dB suitable ear protectors are recommended.

### 3.4 Safety Decals

Safety decals are located on various points of the machine. They can be identified by the yellow upper panel depicting the hazard, and the lower white panel indicating means of avoidance or precautions to be taken. These decals have no text. It is essential that all operators and personnel associated with the machine fully understand their meanings. The decals are shown on the following page.

Any safety decals which are found missing should be replaced.



09.810.01



09.810.02



09.811.05

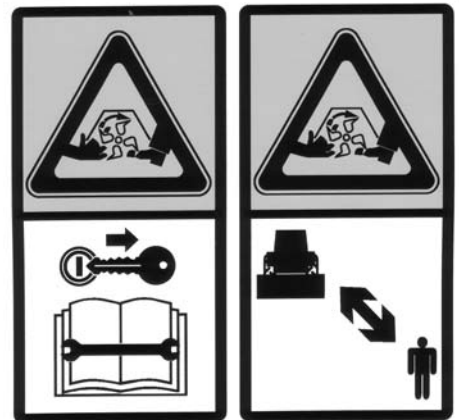

09.821.31



09.821.34



09.843.06

Fig.3

## **4. INSTALLATION**

### **4.1. Tractor Requirements**

Ensure the specifications of the tractor meet the requirements listed below:

- a A PTO output of 1000 rev/min.
- b A Cat II - three point linkage.
- c Adjustable top link.
- d Ballasted weight of tractor should exceed 2500kg

Note If necessary adequate ballast should be added to the rear wheel opposite to the head and to the front of the tractor to ensure stability.

### **4.2. Hydraulic Requirements**

Ensure that the tractor spool valve can provide:

- a Flow 22 - 45 lit/min (5-10 gal/min).
- b Minimum pressure 125 bar (2200 lb/in).
- c Two spools; one double acting one single acting.

### **4.3. Machine Preparation**

- a A machine will normally be delivered fully assembled with the head on the ground and mainframe in the position illustrated in Fig.4.
- b The lifting points are for machines fitted with a transit stay. When lifting in anything other than this condition extreme care should be exercised as the centre of gravity may change
- c Only personnel experienced in lift and hoist operation should attempt repositioning the machine.

**Fig. 4**

#### **4.4. To Move the Machine from The Delivery To Work Position**

- a Position the machine on a hard, flat surface.
- b Attach mainframe to crane using suitable chains/slings.
- c Remove transport stay.
- d Lower mainframe to ground.
- e Level machine with stand if required.
- f Remove crane and check for stability.

#### **4.5. Fitting to Tractor**

Refer to Fig. 5

- a Position the machine on a flat, hard surface
- b Reverse tractor squarely to the machine
- c Carefully reverse the tractor so that the ball joints on the linkage line up with the clevis on the mainframe.
- d Position left lift arm in mounting clevis, fit pin (A) and lock with linch pin and ring.
- e Adjust right lift arm if necessary.
- f Position right lift arm in mounting clevis, fit pin (B) and lock with linch pin and ring.
- g Fit adjustable top link between tractor and top of mainframe (C).
- h Secure with pin provided with tractor.
- i Lift the machine hydraulically until the stands are clear of the ground. Adjust the right lift arm and the top link until the machine is square with the tractor.
- j Raise stands (D) and store by placing the securing pin in the bottom hole of the stand.
- k Fit the tractor check chains to the lift arms and adjust until there is no sideways movement.

**Fig.5**

#### 4.6. Fitting the PTO

Due to the many different makes and sizes of tractor to which BOMFORD TURNER mowers can be fitted, a nominal length PTO shaft is supplied with the machine. In some cases it may be found that this PTO shaft is too long and will have to be shortened - see Fig. 6.

#### IMPORTANT

MINIMUM ENGAGEMENT OF PTO IS 150MM IN THE WORKING POSITION. THIS MEASUREMENT MUST BE TAKEN INTO ACCOUNT WHEN SHORTENING THE PTO SHAFT. (See illustration below) MINIMUM ENGAGEMENT OF THE PTO MUST BE CHECKED THROUGHOUT THE RANGE OF OFFSET OF THE MACHINE.

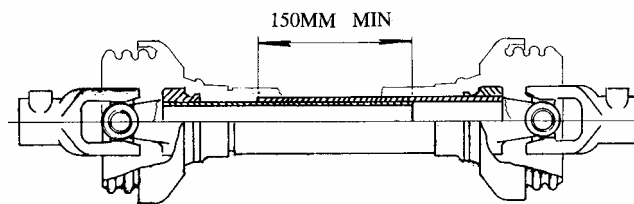

Fig. 6

Before fitting the PTO shaft to the tractor, grease the sliding drive shafts and bearing units.

- a Fit PTO to tractor ensuring locking peg on the splined coupling is fully engaged.
- b Attach PTO guard check chains to the tractor and machine.

#### 4.7 Connecting the Hydraulics

Connect the three hydraulic hoses to the spool valve fittings. To establish the position and type of fitting refer to the tractor instruction manual. IF IN DOUBT CONSULT YOUR LOCAL DEALER.

NOTE: If your tractor has no suitable hydraulic system contact BOMFORD TURNER SERVICE DEPARTMENT

### 5. GUARDS

#### 5.1 Safety Guarding

It is essential that, in the interests of safety, all guards and the roller must be kept in position on the machine whenever the machine is running. The roller is an integral part of the machines guarding and the machine must not be used with the roller missing. Bomford Turner Ltd disclaim all responsibility for any damage or injury arising as a result of guards or roller being removed, or of guards other than of Bomford Turner manufacture having been fitted, or of operation of the machine other than in accordance with these instructions.

#### 5.2 Inspection of Guards

Inspect guards twice daily when the machine is use or immediately damage is suspected. Replace guards that have damage or wear which could impair their performance, as follows:

- a **STEEL GUARD:** distorted or with sharp outer edges.
- b **WIRE TRAP GUARD:** with bent, missing or blunt cutting edge.
- c **FLEXIBLE GUARD:** with missing portions, damaged, or worn sufficiently to permit stones or other objects to be ejected beneath it in normal conditions.
- d **PTO GUARDS:** missing or damaged.

- e **MACHINE GUARDS:** missing or not secured properly

IF IN DOUBT CONSULT BOMFORD TURNER SERVICE DEPARTMENT

## **6. OPERATION**

### **6.1. Initial Checks**

Check that the machine is correctly attached to the tractor and that the tractor is equipped to deliver 1000 rev/min at the power take-off shaft. **IN NO CIRCUMSTANCES MUST THE PTO EXCEED 1050 REV/MIN.**

### **6.2 Normal Pre-start Checks**

- a Check that the rotor shaft is free from obstructions, especially pieces of wire.
- b Check that all flails are in good condition and securely attached to the shaft.
- c Check that all guards are in their correct places and in good condition. See paragraph 5.2
- d Check that the roller is in place and correctly adjusted to the required height.
- e Examine the area to be cut. It is very important that the work site is inspected before cutting and all hidden obstructions removed or their position marked so that these may be avoided.
- f Check ditches for tree stumps, drain pipes, large stones, etc.

### **6.3 Initial Run Up**

- a Raise the rotor unit off the ground using the hydraulics.
- b Ensure nobody is standing near to the machine.
- c Run tractors engine at idle speed and engage PTO drive.
- d When rotor starts increase PTO speed gradually to 1000 rev/min.
- e If rotor fails to start stop tractor engine; check PTO drive and belt tension.
- f Allow the machine to run for approximately ten minutes.
- g Stop the machine immediately if excessive noise is heard or vibration is felt and refer to Maintenance section.

### **6.4 Normal Run Up**

- a With a new machine never start cutting in arduous conditions. Allow at least one day's light work for running in.
- b Never attempt to start the machine while it is under load at any time. Always free rotor shaft from any obstructions.
- c Never increase or decrease PTO speed rapidly as this can lead to gearbox damage.

**IMPORTANT. STOP RUN UP IMMEDIATELY IF NOISE IS DETECTED FROM THE ROTOR SHAFT OR GEARBOXES, INVESTIGATE CAUSE AND REFER TO MAINTENANCE AND SAFETY PRECAUTIONS' SECTIONS. FAILURE TO STOP MACHINE MAY CAUSE SERIOUS DAMAGE**

### **6.5 Stalling the Rotor**

If the rotor becomes choked the tractor will stall or the belts will slip. If this occurs follow the instructions below:

- a Stop forward motion, disengage PTO drive immediately and place PTO drive lever in neutral.
- b Ensure that the rotor has stopped and lift the cutting head using the hydraulics.
- c Stop the tractor engine.
- d Remove any obstructions that may be present on the rotor. If working under the raised machine, ensure that it is safely supported.
- e NEVER IN ANY CIRCUMSTANCES run the rotor to clear itself.

### 6.6 Safety Break Back

Between the Mainframe and the Arm assembly two links allow the machine to pivot during offsetting. One link assembly has a large internal spring. This allows the link to open and the head to pivot back should any major obstruction be encountered during work. The operator should stop, reverse away from the obstruction and raise the machine before continuing in the direction of work. This allows the link assembly to reset and the machine will return to its normal working position.

### 6.7 Roller Height

The roller is pre-set in its raised position before leaving the factory. The method of adjustment is detailed in the section on Maintenance.

### 6.8 Transporting The Machine To & From Work

Normally the machine will need to be driven to the work site before commencing work. To keep the machine/tractor width to a minimum it will be necessary to place the machine in the transport position. This is described below and illustrated in Fig.7

- a The tractor must be stationary.
- b Retract the cutting head ram to raise the cutting head vertically.
- c Retract the offset ram to bring the machine in line with the tractor.
- d Disengage the PTO drive.
- e Fit transport stay between the arm and cutting head.
- f To remove machine from the transport position the above sequence is reversed.

**WARNING!** Do not transport the machine on the public highway without the transport stay fitted. Ensure that the PTO is disconnected.

**Fig.7**

*Transport Stay*





## **6.9 Storage**

Before removing the machine from the tractor a thorough check should be made, as follows:

- a Thoroughly clean all moving parts, particularly the rotor unit.
- b Check all flails are in place and that they are in good condition.
- c Check all hoses for damage such as cracks, evidence of chafing and leaks.
- d Slacken off tension from drive belts.
- e Smear all unpainted metal parts with grease and lubricate all grease nipples.
- f Make a note of any item that needs replacing so that parts can be ordered.

## **6.10 Parking and Removal**

In the parked position the machine is supported by three stands on the mainframe and arm and also by the cutting head.

- a Place the cutting head on the ground.
- b Disengage PTO drive
- c Lift the mainframe on the tractor lift arms, lower stands and pin in position.
- d Lower mainframe on to its stands.
- e Stop tractor engine and operate control valve levers in both directions to release pressure.
- f Disconnect hydraulic hoses and fit dust caps to exposed ends
- g Release tractor end of PTO shaft, pull back along splines and release from shaft.
- h Slacken lift arms and check chains.
- i Slacken adjustable top link and remove.
- j Remove linch pin and rings securing lift arms to mounting pins.
- k Remove lift arms from mounting pins.
- l Start tractor and drive carefully forward, releasing machine and PTO shaft from tractor.
- m Replace lower link pins, ensuring breakout link is pinned to the mainframe.
- n Place cap over tractor PTO.
- o Remove the machine PTO and store in a safe place.

## **7 MAINTENANCE**

### **7.1 Roller Height Adjustment**

- a Raise the cutting head off the ground.
- b Stop tractor engine and disengage PTO drive.
- c Place a strong support under the side skids.
- d Slacken off the pivot bolts of the roller bracket.
- e Remove remaining bolts and nut from roller bracket.
- f Lower or raise the roller to the height required.
- g Replace bolts in required hole.
- h Fully tighten all nuts on both sides.
- i Remove support and lower the cutting head to the ground.

### **IMPORTANT**

THE ROLLER MUST BE KEPT IN POSITION AT ALL TIMES AS IT IS AN ESSENTIAL PART OF THE CUTTING HEAD GUARDING

### **7.2 Hoses**

It is false economy to try and make a damaged hose last a bit longer, because a failure can spill several gallons of oil on the road, endangering traffic and the environment. To reduce the risk of this happening and ensure a long life from the hoses, follow instructions given below.

- a Check weekly that all hoses and their connections are in good condition and that there are no leaks or damage.
- b Replace any hose that is leaking or damaged.
- c Ensure that hoses have not chafed against sharp edges.
- d Re-route any hose that has been chafing
- e If in doubt about the condition of any hose REPLACE IT.

### **7.3 Fitting Replacement Hydraulic Hoses**

It is important that hoses are fitted and aligned correctly. Hoses should never be twisted or kinked. On most hoses there is a line which runs the full length of the hose which acts as a useful guide. If there is no guide line along the hose follow the fitting instructions below. (See Fig. 8)

- a Attach angled end of hose to its coupling but do not tighten. Either end can be attached if both ends of hose are straight, although most hoses on BOMFORD TURNER machines have one end with an angle bend.
- b Position the hose to its required route.
- c Connect other end loosely to its union.

- d Tighten angled end of hose in required position.
- e Tighten straight end. It may be found that as the nut is tightened the hose may twist slightly. If this happens follow instruction (f), if it does not twist follow from instruction (h).
- f Slacken off nut and turn hose in opposite direction to that of the twist.
- g Retighten nut and bring hose back centrally.
- h Tighten hose clamps and clips where applicable.
- i Finally, operate the machine to all positions to ensure that the hoses are clear of any obstructions and also that the pipes are not pulling tight due to being clamped up incorrectly.
- j Always give plenty of clearance around sharp edges.

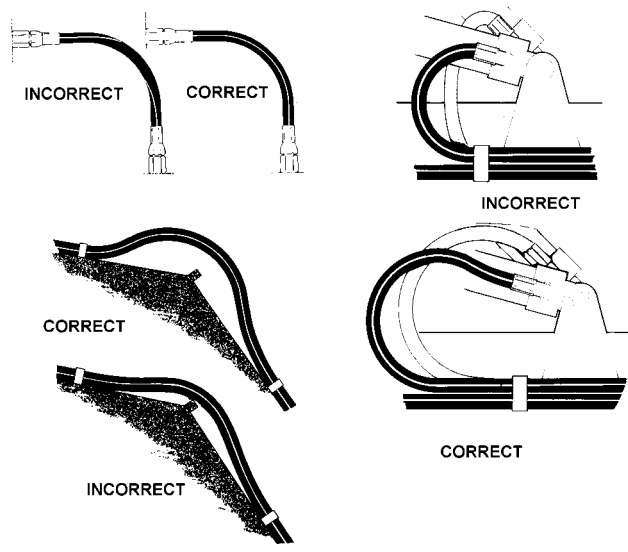

Fig.8

#### 7.4 PTO Shaft

The PTO shaft used is of the normal agricultural type. Spares kits comprising the spider, needle bearings, circlips, etc. are available from most agricultural dealers.

For correct part numbers, that must be quoted when ordering spares, see replacement parts section of this manual.

Some routine maintenance is needed to ensure a trouble free life for the PTO shaft. For best results:

- a Grease PTO shaft sliding tubes regularly.
- b Grease both ends of PTO shaft daily.
- c Ensure check chains are securely attached and in good condition.
- d Check that the PTO guard is in good condition and replace it if not.
- e Check universal joint bearing journals for roughness or slackness. Replace if necessary.

#### 7.5 Lubrication

Any good quality lithium based grease may be used for lubrication of pivot pins and bearings.

There are a number of greasing points on the machine. The frequency at which these points should be greased is indicated on the decal adjacent to the grease point. A typical decal is illustrated in Fig.9

**Fig.9**

Make greasing easier by relieving the weight from the pivot pins. Rest the cutting head on the ground, stop tractor engine and operate controls in both directions to release pressure in rams.

Do not over grease the roller and its bearings or the carriers may be forced apart and distorted by the pressure.

### 7.6 To Grease the Rotor Shaft Bearings

- a Place head on ground or support it safely.
- b Stop tractor engine and disengage drive to PTO shaft.
- c Rotor shaft bearings - grease nipples are located through a cut out in the drive guards.
- d Apply grease to the nipples but do not grease violently as damage to the seals may result.
- e Do not over grease or it could cause overheating.

### 7.7 Gearbox Lubrication

Main Gearbox	Capacity 2.3 litres	Oil Type - SAE90 EP
Swivel Gearbox	Capacity 1.9 litres + 1.7 litres	Oil Type - SAE90 EP

Check the oil levels before use and then every 8 - 10 hours during use. Do not over fill.

NOTE: Overfilling the gearbox will result in pressure build up and cause oil seals to leak.

Change oil after first 50 hours operation then every 500 hours or yearly which ever occurs sooner.

### 7.8 Drive Belts

The rotor shaft is driven from the gearbox via 'V' belts that are adjustable for tension. The belts are tensioned by an idler pulley running on the inside of the belts and are adjusted as detailed below. Refer to Fig.10

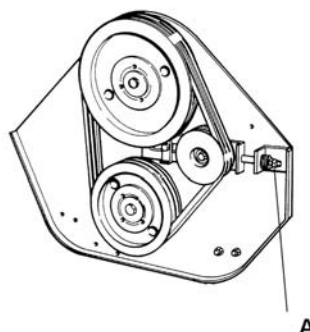
**Fig.10**

- a Lower the machine to the ground using the hydraulics.
- b Stop tractor engine and disengage PTO drive.
- c Remove guard over pulleys. Loosen locknuts and turn locknut (A) on outside of idler pulley bracket in a clockwise direction to obtain correct tension. The belt tension is correct when the flat washer is level with end of indicator (See Fig.11).
- d Tighten locknuts (A) together.
- e Refit guard.

**IMPORTANT**

ENSURE THE BELTS ARE NOT OVER TIGHT AS THIS MAY CAUSE PREMATURE FAILURE OF THE ROTOR SHAFT BEARINGS AND BELTS.

Fig.11

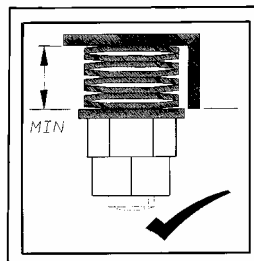

**7.9 Rotor Shaft**

Vibration of the rotor shaft can cause premature failure of the rotor shaft bearings, as well as hydraulic and structural failures. It is important not to operate the machine with the head vibrating. As soon as any vibration is felt stop operating the machine and make the checks listed below:

**WARNING! Flails** - Check each day that flails are in good condition and securely attached to the rotor shaft. Replace any that are damaged and tighten any loose nuts.

- a Disengage PTO drive.
- b Place head vertically using the hydraulics, fit transport strap or support head safely Stop tractor engine.
- c Check flails are in place and the securing nuts and bolts are tight.
- d Check for missing or worn flails. Always replace missing/worn flails in pairs opposite each other to maintain shaft balance.
- e When replacing missing/worn flails check if the retaining bolts are worn or bent. Replace any suspect bolts. Always fit new locknuts and spring washers when replacing flails.
- f If any flails were missing or loose and have been replaced or tightened, lower head run the rotor shaft and retest for vibration. If vibration is still present check rotor shaft bearings as follows.
- g Disengage PTO drive and stop tractor engine.
- h Check rotor shaft bearings for roughness or signs of slackness.
- i Replace bearings if either of the above symptoms are found. If vibration persists it is an indication that the rotor shaft is bent and must therefore be replaced.

**IMPORTANT**

When replacing bearings or changing pulley ratios, ensure the centre bolt retaining the taper lock is fully tightened, before tightening the grub screws holding the taper lock to pulley. Failure to do this may result in the bearing rotating on the shaft journal

**7.10 General**

Check all nuts and bolts for tightness.

**7.11 Fitting the Mulch Bar Kit**

The head of the machine will require holes drilling for the attachment of the mulch bar. The position of the holes is illustrated in Fig.12. The spacer (47496.01 for 1600 machines and 47496.02 for 2000 machines) may be used as a guide.

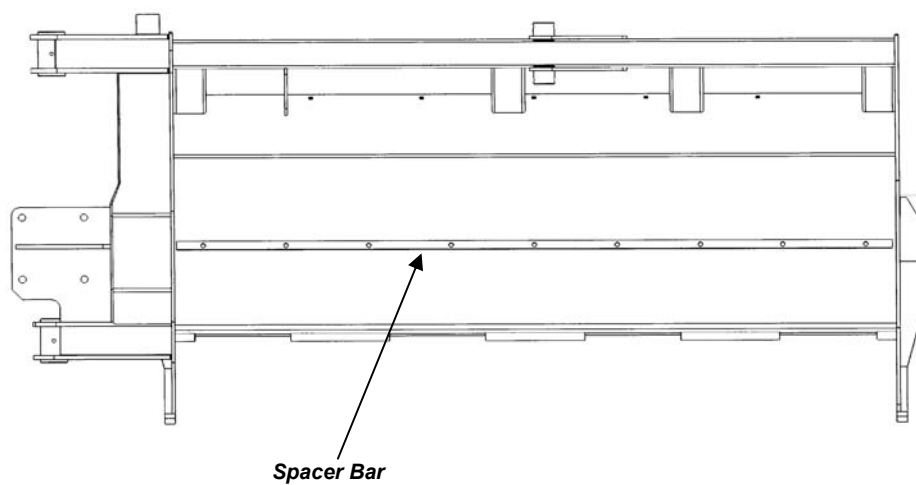

NOTE. The spacer bar may be fitted on the inside or outside of the head depending on the amount of wear on the flails.

The mulch bar must be positioned so that the flails do not contact it when rotating.

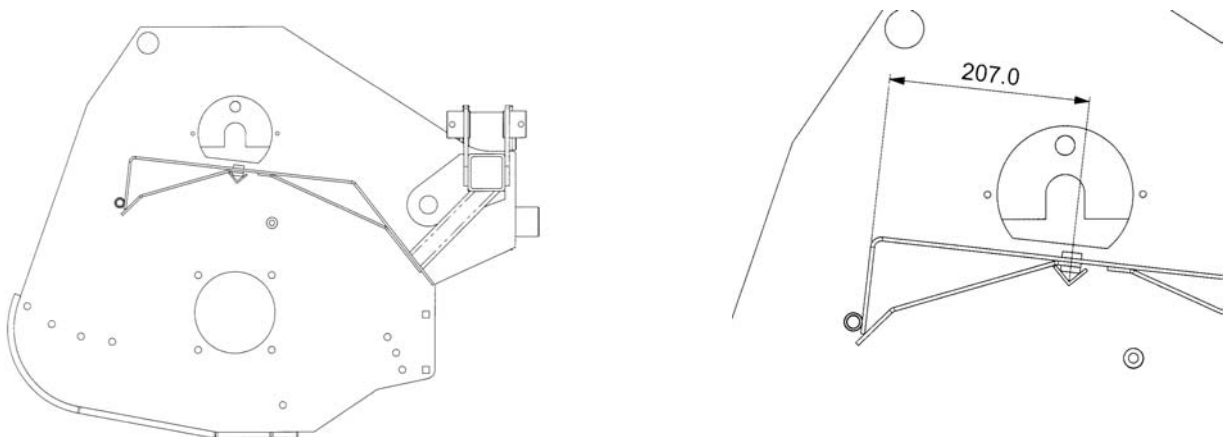
**Fig 12**

# ***Replacement Parts Section***

**For best performance...**

***USE ONLY GENUINE BOMFORD TURNER SERVICE PARTS***

To be assured of the latest design improvements purchase your 'Genuine Replacements' from the Original Equipment Manufacturer through your local Dealer or Stockist.

**Always quote:**

*Machine Type  
Serial Number  
Part Number*

Design Improvements may have altered some of the parts listed in this manual – The latest part will always be supplied when it is interchangeable with an earlier one.

## MAINFRAME & LINKS

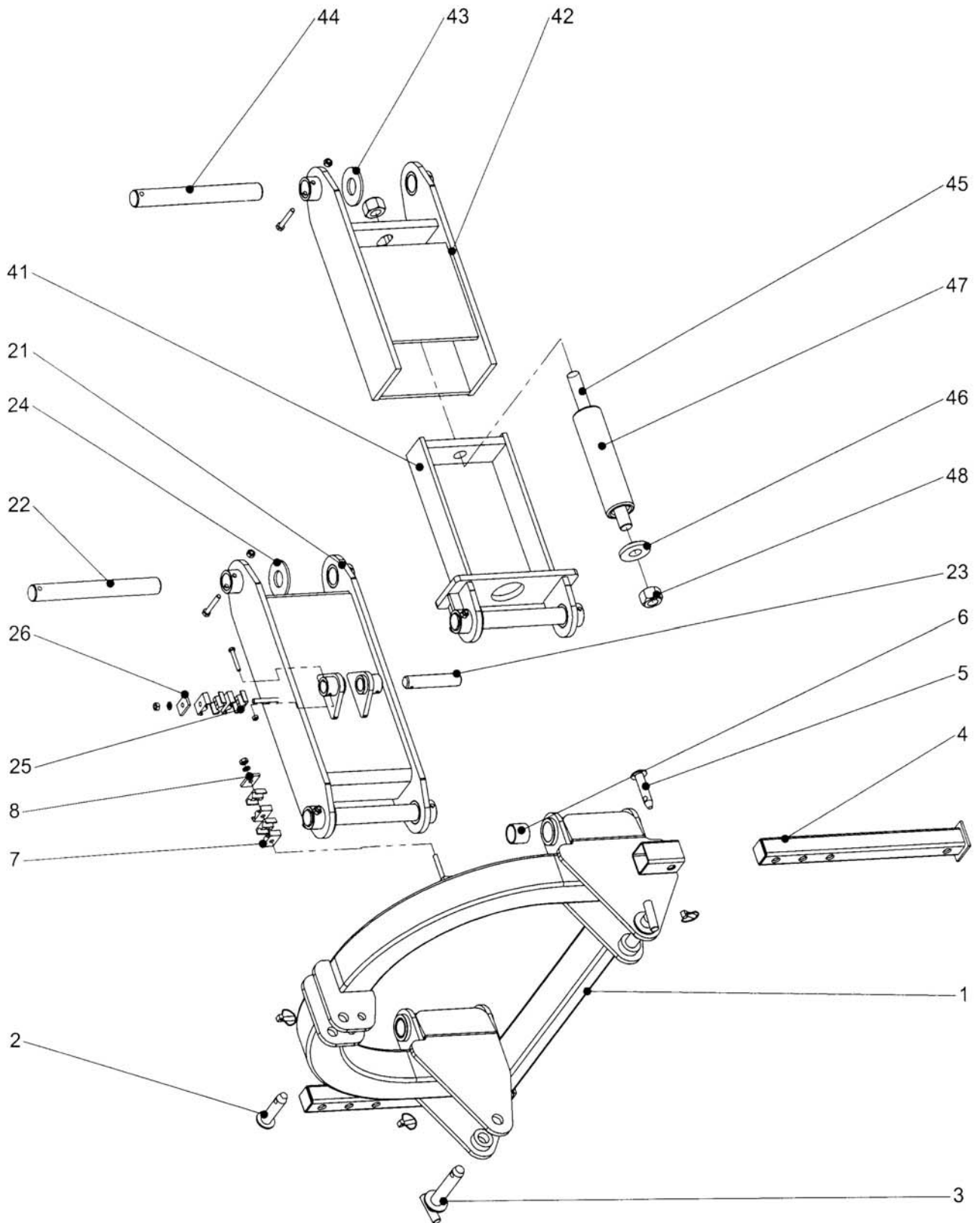





Item	Part No.	Description	Qty.
<b>77.417.01 MAINFRAME ASSY</b>			
01	47443.01	MAINFRAME	1
01	05.227.01	HAMMER DRIVE SCREW NO.6X3/8"	2
01	05.774.07	SERIAL NO. PLATE BOMFORDTURNER	1
01	05.953.04	GREASE NIPPLE M10 90 DEG	2
02	42250.01	PIN-CAT 2 - 1"DIA - 115MM	1
02	00.372.01	LINCH PIN	1
03	41.281.01	PIN 1.1/8"DIA X 140	2
03	00.372.01	LINCH PIN	2
04	47395.01	STAND	2
05	03.652.01	PIN 20 DIA X 90	2
05	00.372.01	LINCH PIN	2
06	08.297.02	BUSH - PLASTIC 47 X 40 X 40	4
07	06.430.07	CLAMP HOSE	4
08	06.418.06	CLAMP PLATE 48 X 6	1
08	04.282.09	STUD M10 X 85MM	1
08	05.282.02	SPRING WASHER 10MM PLATED	1
08	05.286.02	NUT M10 PLATED	1
<b>77.420.01 LINK ASSY FIXED</b>			
21	47439.01	LINK - RAM	1
22	43292.50	PIN 40 DIA X 348	2
22	05.287.02	SELF-LOCKING NUT M10 PLATED	2
22	05.292.11	BOLT M10 X 80MM PLATED	2
23	03.654.69	PIN 30 DIA - 150	1
23	05.287.01	SELF-LOCKING NUT M8 PLATED	1
23	05.291.06	BOLT M8 X 55MM PLATED	1
24	41564.01	THRUST WASHER	4
25	06.430.07	CLAMP HOSE	4
26	06.418.06	CLAMP PLATE 48 X 6	1
26	04.282.09	STUD M10 X 85MM	1
26	05.282.02	SPRING WASHER 10MM PLATED	1
26	05.286.02	NUT M10 PLATED	1
<b>77.419.01 LINK ASSY BREAKOUT</b>			
41	47377.01	LINK - BREAKOUT INNER	1
42	47378.01	LINK - BREAKOUT OUTER	1
43	41564.01	THRUST WASHER	4
44	43292.50	PIN 40 DIA X 348	2
44	05.287.02	SELF-LOCKING NUT M10 PLATED	2
44	05.292.11	BOLT M10 X 80MM PLATED	2
45	46440.01	SPRING GUIDE BAR	1
46	03.851.01	COLLAR 75DIA X 20MM	1
47	03.865.02	SPRING-COMP. 70 DIA X 275MM	1
48	05.287.07	SELF-LOCKING NUT M30	2

## ARM ASSEMBLY

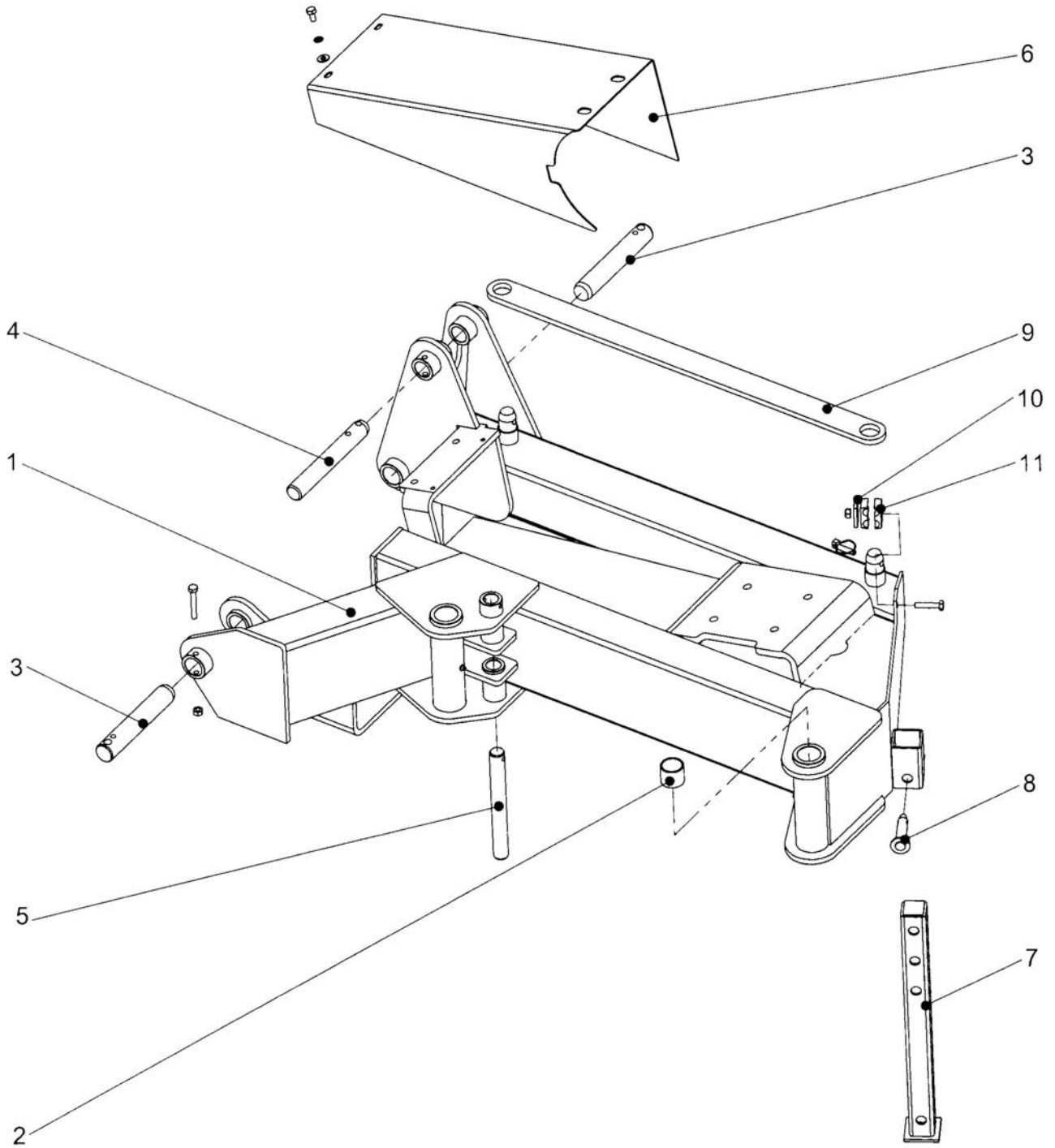



Item	Part No.	Description	Qty.
<b>77.418.01/02 ARM ASSY RH/LH REAR</b>			
01	47372.01	ARM LH REAR	1
01	47372.02	ARM RH REAR	1
01	00.372.01	LINCH PIN	2
01	05.953.03	GREASE NIPPLE M10	2
02	08.297.02	BUSH - PLASTIC 47 X 40 X 40	4
03	46447.02	PIN 40 DIA X 230	2
03	05.287.02	SELF-LOCKING NUT M10 PLATED	2
03	05.291.19	BOLT M10 X 70MM PLATED	2
04	46446.01	PIN 35DIA- 250	1
04	05.287.02	SELF-LOCKING NUT M10 PLATED	1
04	05.291.18	BOLT M10 X 65 PLATED	1
05	03.654.74	PIN 30DIA X 260	1
05	05.287.01	SELF-LOCKING NUT M8 PLATED	1
05	05.291.06	BOLT M8 X 55MM PLATED	1
06	47482.01	GUARD - DRIVE LH	1
06	47482.02	GUARD - DRIVE RH	1
06	05.264.11	SETSCREW M10 X 20MM PLATED	2
06	05.281.02	FLAT WASHER 10MM PLATED	2
06	05.282.02	SPRING WASHER 10MM PLATED	2
07	47395.01	STAND	1
08	03.652.01	PIN 20 DIA X 90	1
08	00.372.01	LINCH PIN	1
09	47451.01	STRAP - TRANSPORT	1
10	06.430.07	CLAMP HOSE	2
10	05.282.02	SPRING WASHER 10MM PLATED	1
10	05.286.02	NUT M10 PLATED	1
10	05.291.15	BOLT M10 X 50MM PLATED	1
11	06.418.06	CLAMP PLATE 48 X 6	1

## CUTTING HEAD 1600

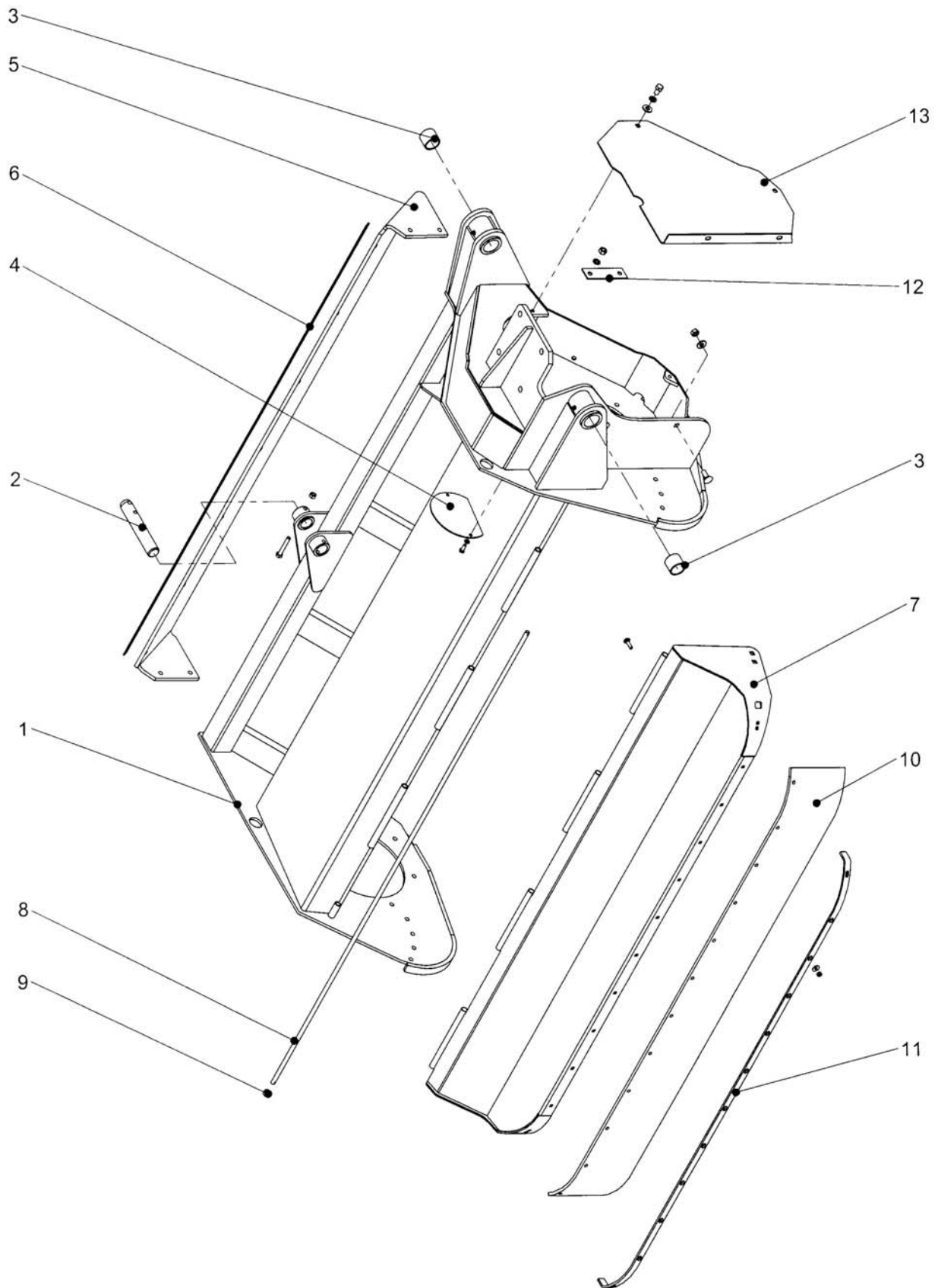



Item	Part No.	Description	Qty.
<b>77.415.02 CUTTING HEAD ASSY 1600 LH/RH REAR</b>			
01	47380.01	CUTTING HEAD 1600 LH REAR	1
01	47380.02	CUTTING HEAD 1600 RH REAR	1
01	05.953.03	GREASE NIPPLE M10	2
02	46445.01	PIN DIA 35 X 200	1
02	05.287.02	SELF-LOCKING NUT M10 PLATED	1
02	05.291.18	BOLT M10 X 65 PLATED	1
03	08.297.02	BUSH - PLASTIC 47 X 40 X 40	4
04	46369.02	PLATE - COVER	1
04	05.264.01	SETSCREW M8 X 20MM PLATED	2
04	05.282.01	SPRING WASHER 8MM PLATED	2
05	42127.01	GUARD - FLEXIBLE 1600	1
06	05.287.01	SELF-LOCKING NUT M8 PLATED	7
06	10.120.01	BACKING STRIP	1
06	9293054	BOLT CUP SQUARE M8X25 (PLATE)	7
07	46414.01	GUARD - FRT BC1600	1
07	05.282.03	SPRING WASHER 12MM PLATED	2
07	05.286.03	NUT M12 PLATED	2
07	05.839.27	BOLT CUP SQ M12 X 25 (PLATED)	2
08	42129.04	PIN-PIVOT 10 DIA - 1800MM	1
09	41436.02	SPACER 3/4"DIA - 12MM	2
09	05.201.17	TENSION PIN 3MM X 25MM PLATED	2
10	46363.02	GUARD - FRONT FLEXIBLE 1600	1
11	46362.02	STRAP-FRONT 1600 6MM PLATE	1
11	05.281.01	FLAT WASHER 8MM PLATED	12
11	05.287.01	SELF-LOCKING NUT M8 PLATED	12
11	9293064	BOLT CUP SQUARE M8X30 (PLATED)	12
12	41418.01	CLAMP - GUARD	2
12	05.282.03	SPRING WASHER 12MM PLATED	4
12	05.286.03	NUT M12 PLATED	4
12	05.839.34	BOLT CUP SQ M12 X 35 (PLATED)	4
13	47387.01	GUARD - DRIVE LH	1
13	47387.02	GUARD - DRIVE RH	1
13	05.264.12	SETSCREW M10 X 25MM PLATED	2
13	05.281.02	FLAT WASHER 10MM PLATED	2
13	05.281.03	FLAT WASHER 12MM PLATED	2
13	05.282.02	SPRING WASHER 10MM PLATED	2
13	05.282.03	SPRING WASHER 12MM PLATED	2
13	05.286.03	NUT M12 PLATED	2
13	05.839.34	BOLT CUP SQ M12 X 35 (PLATED)	2

## **CUTTING HEAD 2000**

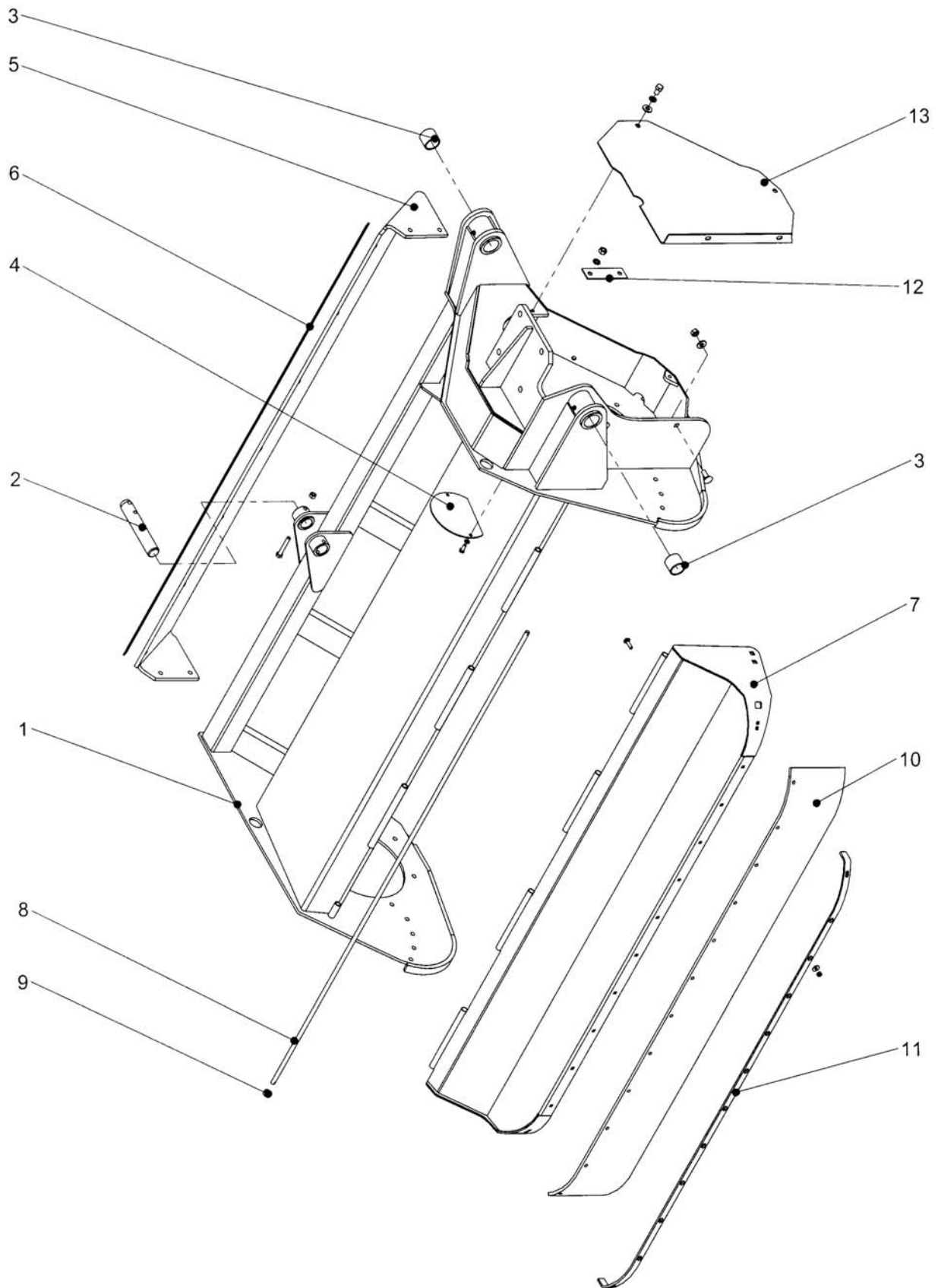



Item	Part No.	Description	Qty.
<b>77.415.03/04 CUTTING HEAD ASSY 2000 LH/RH REAR 10267</b>			
01	47481.01	CUTTING HEAD - 2000 LH REAR	1
01	47481.02	CUTTING HEAD - 2000 RH REAR	1
01	05.953.03	GREASE NIPPLE M10	2
02	46445.01	PIN DIA 35 X 200	1
02	05.287.02	SELF-LOCKING NUT M10 PLATED	1
02	05.291.18	BOLT M10 X 65 PLATED	1
03	08.297.02	BUSH - PLASTIC 47 X 40 X 40	4
04	46369.02	PLATE - COVER	1
04	05.264.01	SETSCREW M8 X 20MM PLATED	2
04	05.282.01	SPRING WASHER 8MM PLATED	2
05	41452.01	GUARD - FLEXIBLE 2000	1
06	41.237.01	BACKING STRIP	1
06	05.287.01	SELF-LOCKING NUT M8 PLATED	8
06	9293054	BOLT CUP SQUARE M8X25 (PLATE)	7
07	46414.02	GUARD - FRONT 2000	1
07	05.282.03	SPRING WASHER 12MM PLATED	2
07	05.286.03	NUT M12 PLATED	2
07	05.839.27	BOLT CUP SQ M12 X 25 (PLATED)	2
08	42129.05	PIN PIVOT 10 DIA - 2170MM	1
09	41436.02	SPACER 3/4"DIA - 12MM	2
09	05.201.17	TENSION PIN 3MM X 25MM PLATED	2
10	46363.01	GUARD - FLEXIBLE FRONT 2000	1
11	46362.01	BACKING STRIP	1
11	05.281.01	FLAT WASHER 8MM PLATED	14
11	05.287.01	SELF-LOCKING NUT M8 PLATED	15
11	9293064	BOLT CUP SQUARE M8X30 (PLATED)	12
12	41418.01	CLAMP - GUARD	2
12	05.282.03	SPRING WASHER 12MM PLATED	4
12	05.286.03	NUT M12 PLATED	4
12	05.839.34	BOLT CUP SQ M12 X 35 (PLATED)	4
13	47387.01	GUARD - DRIVE LH	1
13	47387.02	GUARD - DRIVE RH	1
13	05.264.21	SETSCREW M12 X 20MM PLATED	2
13	05.281.02	FLT WASHER 10MM PLATED FORM C	2
13	05.281.03	FLAT WASHER 12MM PLATED	2
13	05.282.03	SPRING WASHER 12MM PLATED	4
13	05.286.03	NUT M12 PLATED	2
13	05.839.34	BOLT CUP SQ M12 X 35 (PLATED)	2

## ROLLER ASSEMBLY

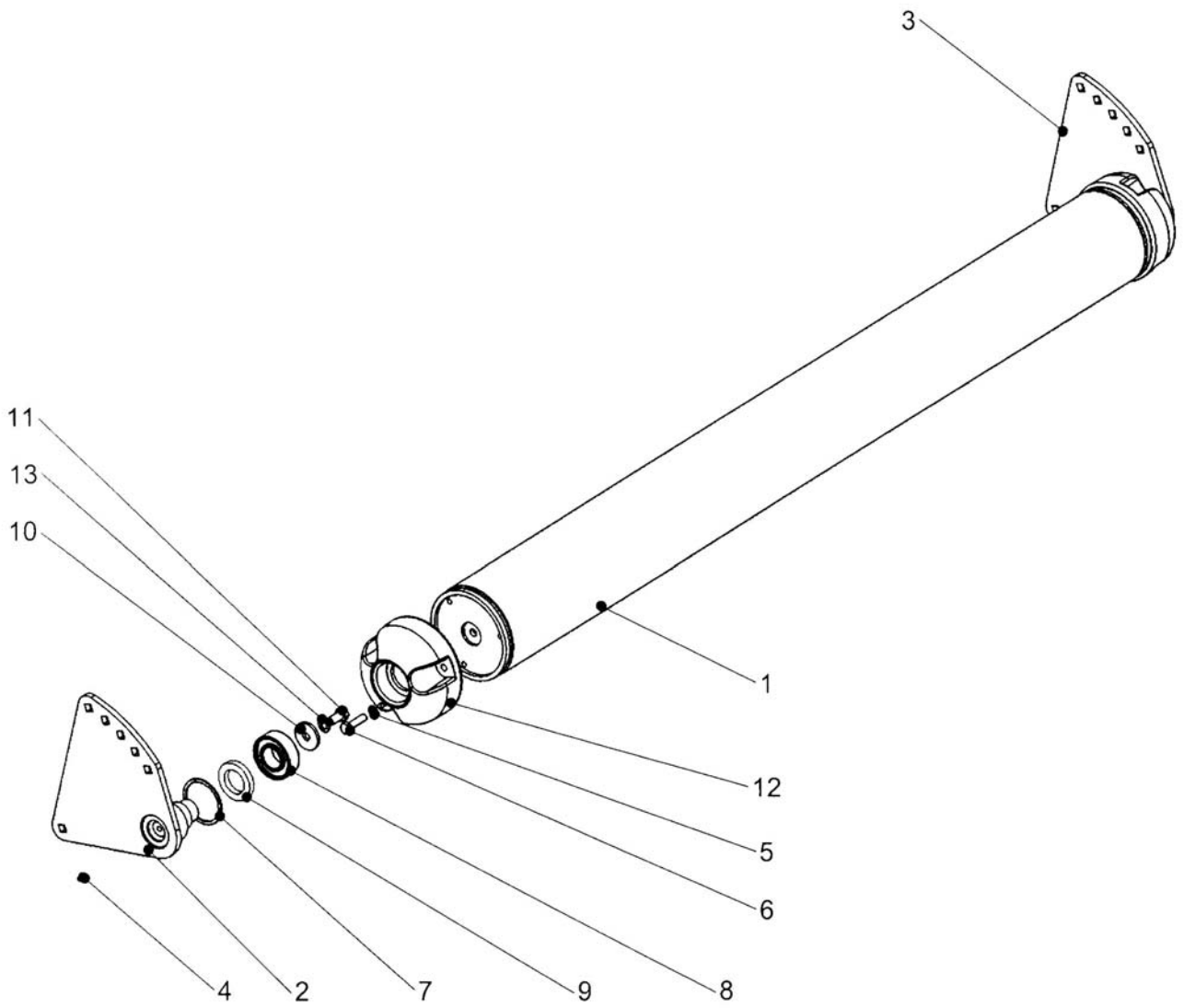





Item	Part No.	Description	Qty.
<b>77.402.01 ROLLER ASSY 150HD 1600</b>			
01	47324.01	ROLLER TUBE (CENTRE)	1
02	47322.01	ROLLER BRACKET LH HD CONDOR	1
03	47322.02	ROLLER BRACKET RH HD CONDOR	1
04	05.953.03	GREASE NIPPLE M10	2
05	05.283.02	SHAKEPROOF WASHER 10MM PLATED	6
06	05.291.13	BOLT M10 X 40MM PLATED	6
07	05.959.12	CIRCLIP - INT 72MM DIA	2
08	45675.01	BEARING 35MM BORE DIA	2
09	04.164.07	SINGLE LIP SEAL 72OD 45ID X 10	2
10	05.234.01	WASHER 44.5 X 13 X 5MM PLATED	2
11	03.068.01	SPECIAL SETSCREW M12 X 25	2
12	45323.01	ROLLER END	2
13	05.282.03	SPRING WASHER 12MM PLATED	2

**77.402.02 ROLLER ASSY 150HD 2000**

01	47324.02	ROLLER TUBE (CENTRE)	1
02	47322.01	ROLLER BRACKET LH HD CONDOR	1
03	47322.02	ROLLER BRACKET RH HD CONDOR	1
04	05.953.03	GREASE NIPPLE M10	2
05	05.283.02	SHAKEPROOF WASHER 10MM PLATED	6
06	05.291.13	BOLT M10 X 40MM PLATED	6
07	05.959.12	CIRCLIP - INT 72MM DIA	2
08	45675.01	BEARING 35MM BORE DIA	2
09	04.164.07	SINGLE LIP SEAL 72OD 45ID X 10	2
10	05.234.01	WASHER 44.5 X 13 X 5MM PLATED	2
11	03.068.01	SPECIAL SETSCREW M12 X 25	2
12	45323.01	ROLLER END	2
13	05.282.03	SPRING WASHER 12MM PLATED	2

## RAM ASSEMBLIES

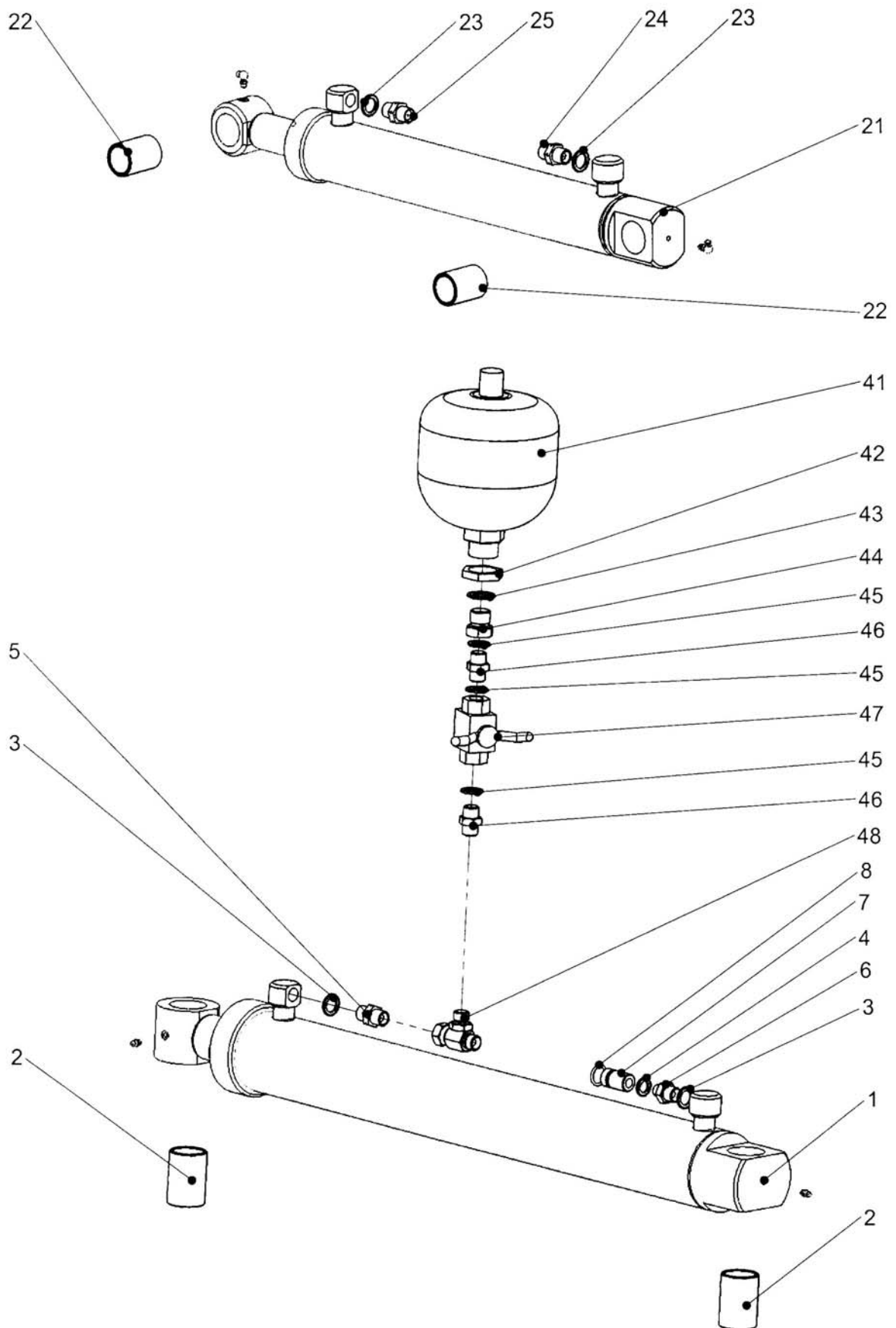



Item	Part No.	Description	Qty.
<b>77.233.02 RAM ASSY - OFFSET</b>			
21	05.953.05	GREASE NIPPLE M6 X 90DEG	2
21	45942.01	RAM ASSY D/A 60 BORE	1
22	08.297.14	PLASTIC BUSH 37 X 30 X 50	2
23	05.290.04	BONDED SEAL 3/8"BSP	2
24	46518.01	RESTRICTOR 3/8"X3/8"BSP 1.27	1
25	46518.15	RESTRICTOR 3/8"X3/8"BSP 1.70	1
<b>77.232.02 RAM ASSY – CUTTING HEAD</b>			
01	05.953.01	GREASE NIPPLE M6	2
01	46002.04	RAM ASSY D/A 80 BORE	1
01	46002.26	SEAL KIT	0
02	08.297.08	PLASTIC BUSH - 42 X 35 X 60	2
03	05.290.04	BONDED SEAL 3/8"BSP	2
04	05.290.02	BONDED SEAL 1/4"BSP	1
05	46518.01	RESTRICTOR 3/8"X3/8"BSP 1.27	1
06	01.099.01	ADAPTOR 3/8"BSP X1/4"BSP	1
07	154.021	BREATHER 1/4" PLATED	1
08	T5222	'O' RING	1
<b>77.117.05 ACCUMLATOR ASSY - CUTTING HEAD RAM</b>			
41	8126043	ACCUMULATOR 1.4LT - 90 BAR	1
42	8126035	M33 BULKHEAD NUT	1
43	8650322	M22 BONDED SEAL	1
44	8581284	ADAPTOR M22 X 3/8"BSP MF	1
45	05.290.04	BONDED SEAL 3/8"BSP	3
46	05.124.01	ADAPTOR 3/8" BSP X 3/8" BSP	2
47	08.200.01	VALVE - ISOLATING 3/8" BSP	1
48	11.068.69	ADAPTOR-TEE 3/8"F X 3/8"M X 3/8"M - BSP	1

## HOSES

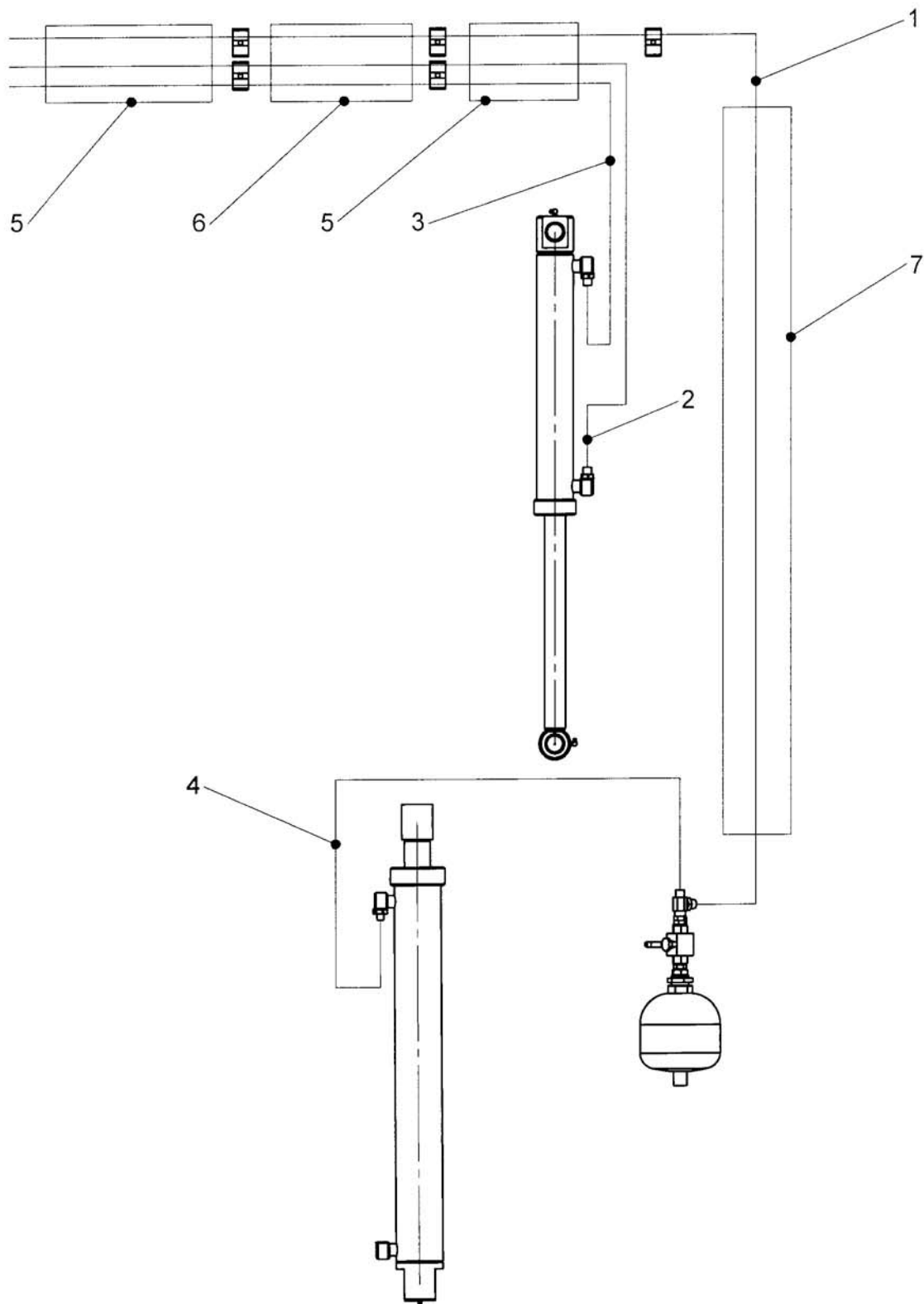



Item	Part No.	Description	Qty.
<b>77.240.02 HOSE KIT</b>			
01	10.003.58	HOSE 3/8" X 4800 LG	1
02	10.003.35	HOSE 3/8" X 2500 LG	1
03	10.003.37	HOSE 3/8" X 2700 LG	1
04	10.004.17	HOSE 3/8" X 850 LG	1
05	43543.01	HOSE SLEEVE	2
06	43543.02	HOSE SLEEVE	1
07	43543.03	HOSE SLEEVE	1
	05.124.01	ADAPTOR 3/8" X 3/8" BSP	3
	05.225.01	ADAPTOR 3/8" X 1/2" BSP REDUCING	3
	05.290.04	BONDED SEAL 3/8"	3
	05.290.05	BONDED SEAL 1/2"	3
	05.300.03	PLUG - PLASTIC 1/2" FEMALE	3

## PTO, INTERMEDIATE SHAFT & GEARBOXES

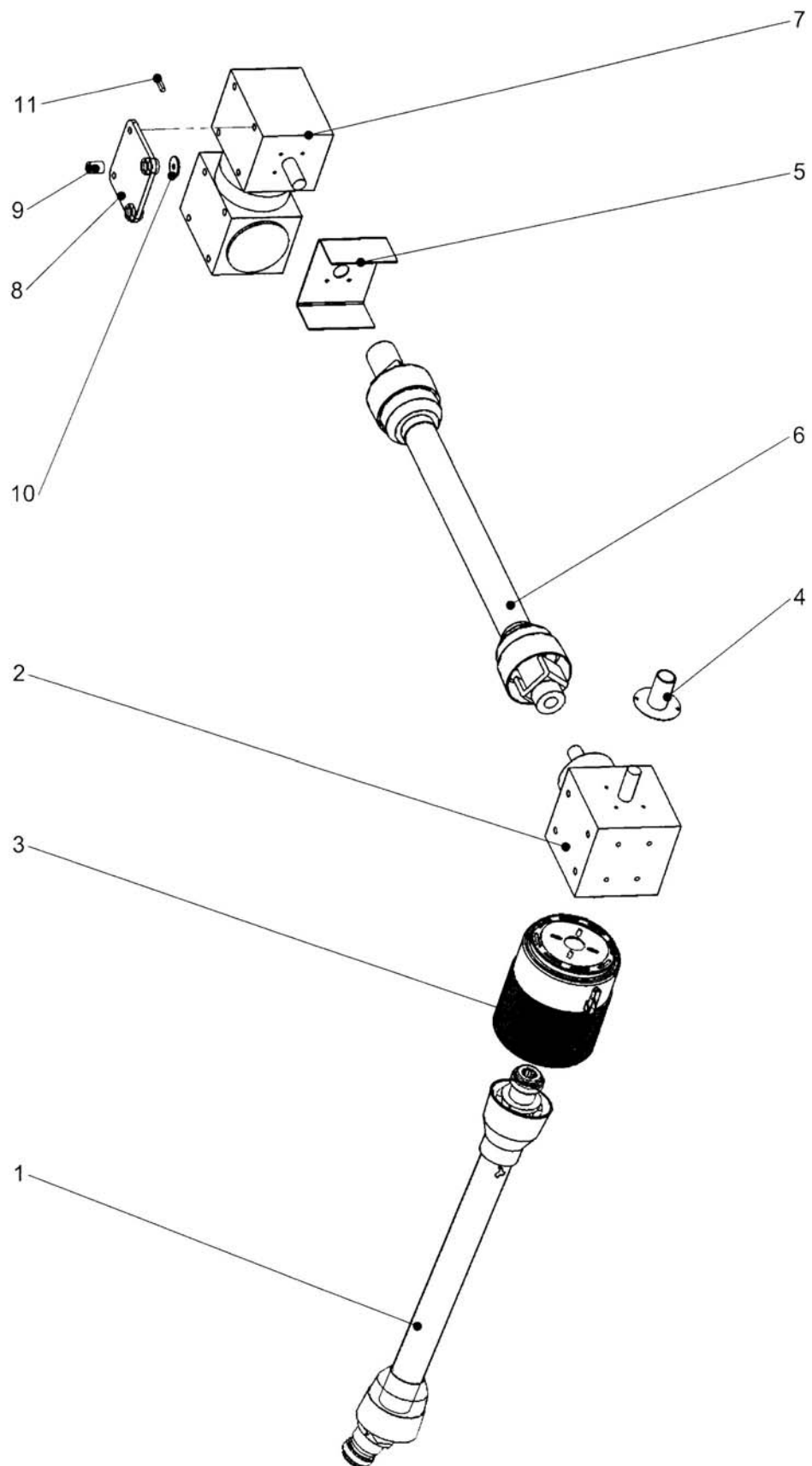



Item	Part No.	Description	Qty.
<b>77.421.01 PTO, INTERMEDIATE SHAFT &amp; GEARBOXES</b>			
01	43602.04	PTO SHAFT 1210 C/C	1
02	47373.01	GEARBOX	1
02	05.264.35	SETSCREW M16 X 40MM PLATED	4
02	05.282.04	SPRING WASHER 16MM PLATED	4
03	21839.01	PTO GUARD ASSY	1
03	05.264.03	SETSCREW M8 X 30MM PLATED	4
03	05.281.01	FLAT WASHER 8MM PLATED	4
03	05.282.01	SPRING WASHER 8MM PLATED	4
04	42668.02	GUARD GEARBOX SHAFT	1
04	05.264.01	SETSCREW M8 X 20MM PLATED	2
04	05.282.01	SPRING WASHER 8MM PLATED	2
05	47424.01	GUARD - GEARBOX	1
05	05.264.01	SETSCREW M8 X 20MM PLATED	4
05	05.282.01	SPRING WASHER 8MM PLATED	4
06	47436.01	SHAFT-DRIVE T60-0310S-345-112	1
07	47371.01	GEARBOX SWIVEL	1
07	05.264.35	SETSCREW M16 X 40MM PLATED	6
07	05.282.04	SPRING WASHER 16MM PLATED	6
08	47401.01	BRACKET - GEARBOX	1
09	03.871.01	RUBBER BUSH	2
09	05.282.03	SPRING WASHER 12MM PLATED	2
09	05.286.03	NUT M12 PLATED	2
09	05.291.30	BOLT M12 X 75MM PLATED	2
10	02.824.01	WASHER 50 O/DX13 I/DX6MM	2
11	05.960.16	KEY-S/REP 12MM X 8MM X 40MM	1

## ROTOR DRIVE & BEARINGS

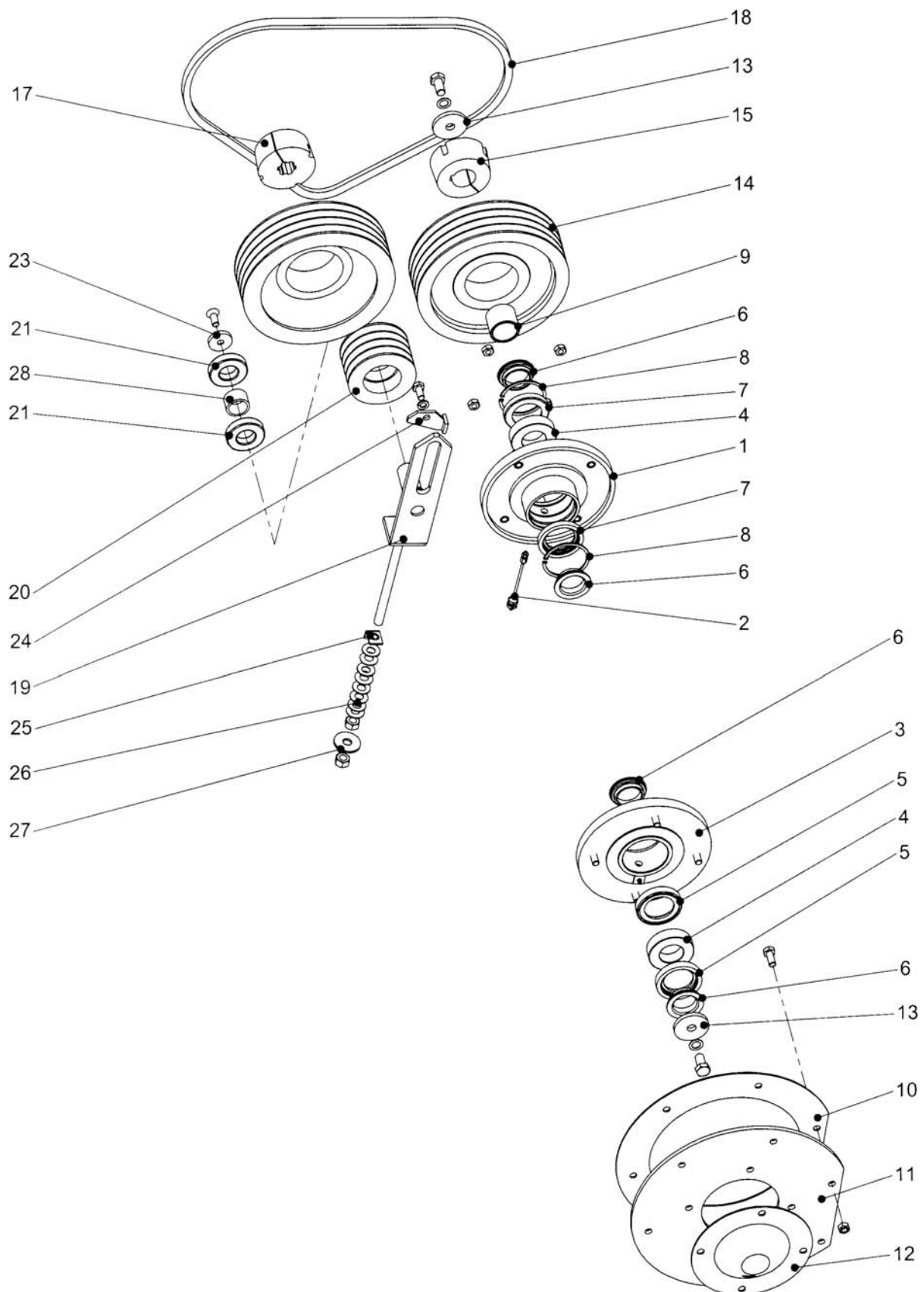





Item	Part No.	Description	Qty.
<b>77.416.01 ROTOR DRIVE AND BEARINGS</b>			
01	46342.03	HOUSING - BEARING DRIVE	1
01	05.968.03	SELF LOCKING NUT M12 (FINE)	4
02	45677.01	GREASING ASSY.- FK COWL D/END	1
03	46342.02	HOUSING - BEARING NON DRIVE	1
03	05.953.01	GREASE NIPPLE M6	1
03	05.968.03	SELF LOCKING NUT M12 (FINE)	4
04	04.163.04	BEARING-SPH.ROLLER 45MM BORE	2
05	43272.01	SPACER-SEAL-STEPPED	2
06	06.910.01	COLLAR-SEAL	4
07	06.909.01	SPACER-SEAL	2
08	05.959.07	CIRCLIP - INT 85MM DIA	2
09	46360.02	SPACER	1
10	46609.01	PLATE - SPACER	1
11	46610.01	PLATE - BEARING MOUNT	1
11	05.264.23	SETSCREW M12 X 30MM PLATED	5
11	05.968.03	SELF LOCKING NUT M12 (FINE)	5
12	00.876.03	COVER - BEARING NON DRIVE 3MM	1
13	04.252.01	WASHER 65 O/D X 17 I/DX8MM	2
13	05.264.33	SETSCREW M16 X 30MM PLATED	2
13	05.283.04	SHAKEPROOF WASHER 16MM PLATED	2
14	42539.03	PULLEY - VEE 280 PCD 4SPB	1
15	42541.02	TAPER LOCK BUSH 45MM BORE 3020	1
15	05.960.13	KEY-S/REP 14MM X 9MM X 45MM	1
16	42539.04	PULLEY - SPECIAL VEE 280 PCD	1
17	42541.03	BUSH - TAPER LOCK 1.3/8" 6 SPL	1
18	05.299.48	BELT-XPB X 1600 QUAD II	4
19	04.399.04	BRACKET - IDLER PULLEY	1
20	46506.01	PULLEY - IDLER 4SPB	1
21	03.007.10	BEARING - BALL 35MM BORE	2
23	47478.01	WASHER	1
23	05.345.09	SOCKET CSK SCREW M12X1.75X30	1
24	04.401.02	PLATE - BRACKET IDLER PULLEY	1
24	05.264.22	SETSCREW M12 X 25MM PLATED	1
24	05.282.03	SPRING WASHER 12MM PLATED	1
25	42929.03	STRAP - DISC ADJUSTMENT	1
26	05.398.05	DISC SPRING 16.3X34X1.5	8
27	45317.01	WASHER - M16 SPECIAL	1
27	05.286.04	NUT M16 PLATED	2
28	47477.01	SPACER	1

## ROTOR SHAFT ASSEMBLY

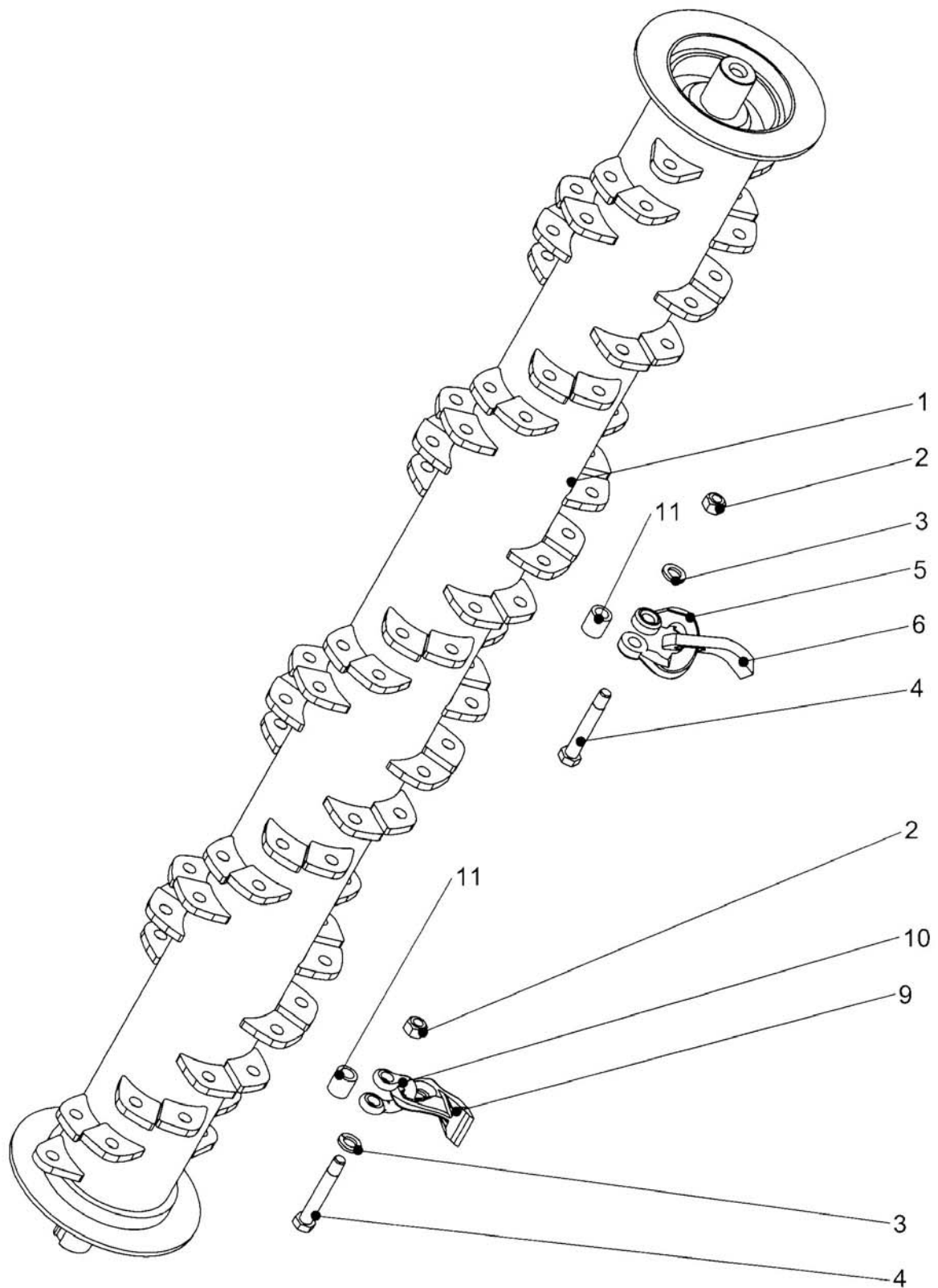



Item	Part No.	Description	Qty.
<b>47403.01/02/03/04 ROTOR SHAFT ASSEMBLY 1600</b>			
01	47402.01	SHAFT – TUBULAR 1600	1
02	05.968.06	SELF LOCKING NUT M14 (FINE)	44
03	05.282.04	SPRING WASHER 16MM	44
04	05.775.10	BOLT – SPECIAL M14 X 96MM	44
05	47202.01	TWISTED SHACKLE	44
06	09.527.01	FLAIL 40 X 12	44
09	42750.01	FLAIL FORGED	44
10	09.518.01	SHACKLE – LONG	44
11	41725.01	SPACER	44

<b>47403.05/06/07/08 ROTOR SHAFT ASSEMBLY 2000</b>			
01	47473.01	SHAFT – TUBULAR 2000	1
02	05.968.06	SELF LOCKING NUT M14 (FINE)	54
03	05.282.04	SPRING WASHER 16MM	54
04	05.775.10	BOLT – SPECIAL M14 X 96MM	54
05	47202.01	TWISTED SHACKLE	54
06	09.527.01	FLAIL 40 X 12	54
09	42750.01	FLAIL FORGED	54
10	09.518.01	SHACKLE – LONG	54
11	41725.01	SPACER	54

## DECALS

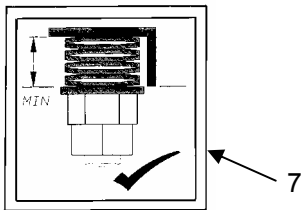
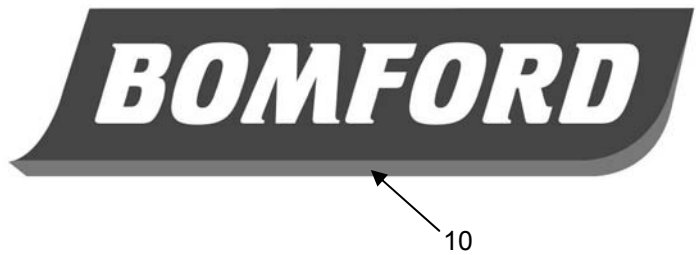
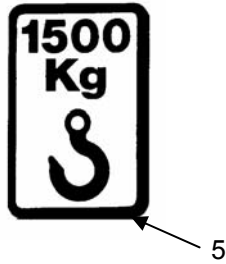
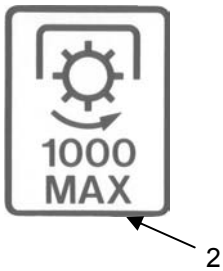
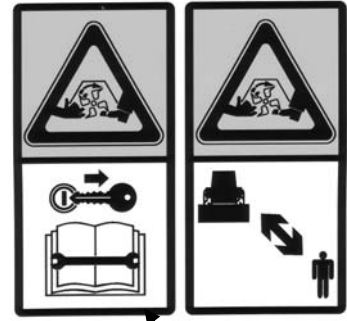
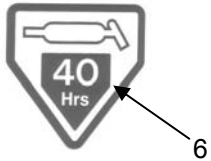

**Turbo VM 2000** 12

**Turbo VM 1600** 11



<u>Item</u>	<u>Part No.</u>	<u>Description</u>	<u>Qty.</u>
<b>77.248.03 DECALS - ENG 10267</b>			
01	09.810.01	DECAL - GREASE (8 HOURS)	4
02	09.811.05	DECAL - MAX PTO SPEED 1000 ACW	1
03	09.821.31	DECAL - EURO DECAL MINATURISED	1
04	09.821.34	DECAL - EURO DECAL MINIATURISED	1
05	09.843.06	DECAL - LIFT POINT 1500 KG	2
06	09.810.02	DECAL - GREASE (40 HOURS)	2
07	42931.01	DECAL - ADJUSTMENT DISC	1
<b>DECALS - MARKETING</b>			
10	45645.01	DECAL - BOMFORD	1
11	47493.01	DECAL - TURBO VM1600	1
12	47493.02	DECAL - TURBO VM2000	1

## MULCHING BAR

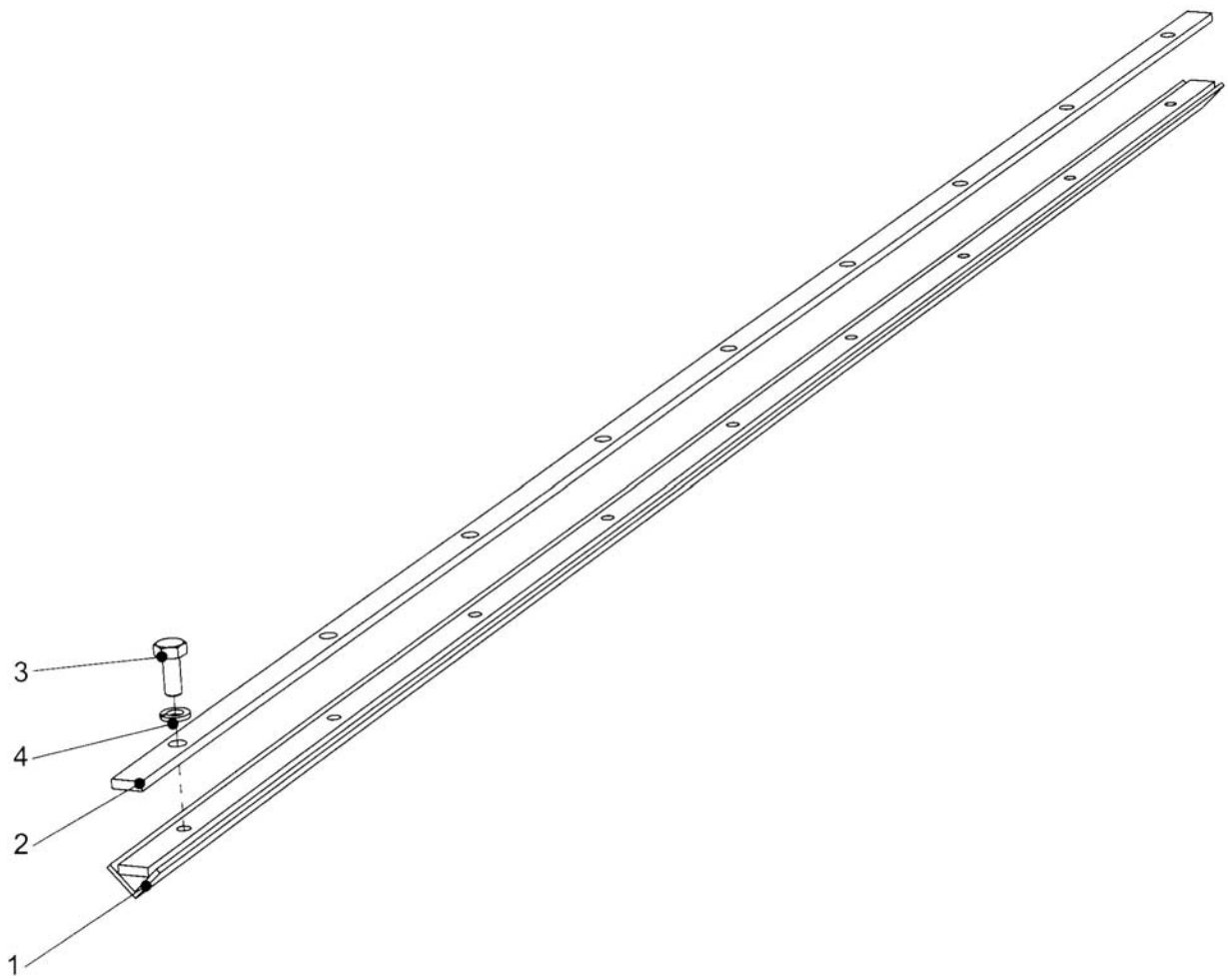



<u>Item</u>	<u>Part No.</u>	<u>Description</u>	<u>Qty.</u>
<b>77.440.01 MULCHING BAR 1600</b>			
01	47461.01	BAR - MULCHING 1600	1
02	47496.01	SPACER - 1600	1
03	05.264.12	SETSCREW M10 X25	9
04	05.282.02	SPRING WASHER	9
<b>77.440.02 MULCHING BAR 2000</b>			
01	47461.02	BAR - MULCHING 2000	1
02	47496.02	SPACER - 2000	1
03	05.264.12	SETSCREW M10 X25	11
04	05.282.02	SPRING WASHER	11