

PM1921

# ***HARRIER***

***4.7P & 5.0P***

**ARM MOWERS**

**PARTS MANUAL**

**ISSUE 5**

## **IMPORTANT**

NOTE HERE THE SERIAL NUMBER OF YOUR MACHINE AND ALWAYS QUOTE IT IN ANY COMMUNICATION WITH US OR YOUR DEALER. THIS IS PARTICULARLY IMPORTANT WHEN ORDERING SPARES. REMEMBER TO INCLUDE ALL NUMBERS AND LETTERS.

MACHINE SERIAL NUMBERS \_\_\_\_\_

THE INFORMATION GIVEN THROUGHOUT THIS MANUAL IS CORRECT AT THE TIME OF PUBLICATION. HOWEVER, IN THE COURSE OF CONSTANT DEVELOPMENT OF BOMFORD TURNER MACHINES, CHANGES IN SPECIFICATION ARE INEVITABLE. SHOULD YOU FIND THE INFORMATION GIVEN IN THIS BOOK TO BE AT VARIANCE WITH THE MACHINE IN YOUR POSSESSION, YOU ARE ADVISED TO CONTACT THE BOMFORD TURNER SERVICE DEPARTMENT WHERE UP-TO-DATE INFORMATION WILL BE PROVIDED.

THE MANUAL CAN CONTAIN STANDARD AND OPTIONAL FEATURES AND IS NOT TO BE USED AS A MACHINE SPECIFICATION.

THE MACHINE HAS BEEN TESTED AND IS CONSIDERED SAFE IF CAREFULLY USED. ENSURE YOUR OPERATOR IS PROPERLY TRAINED IN ITS USE AND MAINTENANCE.

---

## **IMPORTANT**

NOTEZ ICI LES NUMEROS DE SERIE DE VOTRE MACHINE ET MENTIONNEZ LES DANS TOUTE COMMUNICATION AVEC NOS SERVICES OU VOTRE REVENDEUR. CECI EST IMPORTANT POUR LA COMMANDE DE PIECES DETACHEES. PENSEZ A NOTER TOUS LES NUMEROS ET TOUTES LES LETTERS.

NUMEROS DE SERIE DE LA MACHINE \_\_\_\_\_

LES INFORMATIONS DONNEES DANS CE MANUEL SONT CORRECTES CEPENDANT, DU FAIT DE DEVELOPPEMENT CONSTANT DES MACHINES BOMFORD TURNER.

CHANGEMENTS DANS LES CARACTERISTIQUES SONT INEVITABLES.

SI VOUS TROUVEZ QUE LES INFORMATIONS DONNEES NE CORRESPONDENT PAS A VOTRE MACHINE VEUILLEZ CONTACTER LE SERVICE DES REPARATIONS OU DES INFORMATIONS PLUS RECENTES VOUS SERONT DONNEES.

CE MANUEL PEUT MONTRER DES CARACTERISTIQUES OPTIONNELLES ET NE PEUT PAS ETRE CONSIDERE COMME SPECIFICATION DE LA MACHINE.

CETTE MACHINE A ETE TESTEE, ET ELLE EST CONSIDEREE COMME FIABLE A CONDITION D'UNE BONNE UTILISATION. ASSUREZ-VOUS QUE VOTRE OPERATEUR EST QUALIFIE EN CE QUI CONCERNE L'UTILISATION DE LA MACHINE AINSI QUE SON ENTRETIEN.

---

## **WICHTIG**

TRAGEN SIE HIER DIE SERIENNUMMERN IHRER MASCHINE EIN UND GEBEN SIE DIESE IMMER AN, WENN SIE SICH AN UNS ODER IHREN HÄNDLER WENDEN. DAS IST BESONDERS BEI ERSATZTEILBESTELLUNGEN WICHTIG. VERGESSEN SIE NICHT, ALLE ZAHLEN UND BUCHSTABEN ZU NOTIEREN.

SERIENNUMMERN DER MASCHINE \_\_\_\_\_

DIE ANGABEN INDIESEM HANDBUCH SIND BEI VERÖFFENTLICHUNG KORREKT. AUFGRUND DER KONSTANTEN WEITERENTWICKLUNG VON BOMFORD TURNER MASCHINEN SIND JEDOCHÄNDERUGDEN IN DER SPEZIFIKATION UNVERMEIDLICH. WENN DIE INFORMATION IN DIESEM HANDBUCH NICHT MIT IHRER MASCHINE ÜBEREINSTIMMEN, NEHMEN SIE BITTE KONTAKT MIT DER BOMFORD TURNER KUNDENDIENSTABTEILUNG AUF, DIE IHNEN GERNE DIE AKTUELLEN INFORMATION ZUKOMMEN LÄSST.

DAS HANDBUCH KANN SOWOHL BESCHREIBUNGEN FÜR DIE STANDARD AUSFÜHRUNG ALS AUCH FÜR ZUBEHÖR ENTHALTEN UND IST NICHT ALS MASCHINENSPEZIFIKATION ZU VERWENDET.

DIE MASCHINE IST GETESTET UND BEI SACHGEMÄSSEM BETRIEB ALS SICHER BEFUNDEN WORDEN. SORGEN SIE DAFÜR, DASS IHR BEDIENPERSONAL IN ANWENDUNG UND WARTUNG RICHTIG GESCHULT WIRD.

### HARRIER RANGE OF ARM MOWERS

PAGE ILLUSTRATION NUMBERS SHOWN ARE USED ONLY FOR REFERENCE PURPOSES  
AND SHOULD NOT BE USED FOR ORDERING SPARE PARTS.  
PLEASE ENSURE THE CORRECT PART NUMBER AND DESCRIPTION IS GIVEN WHEN  
ORDERING SPARE PARTS.

*For Machines with Serial Numbers commencing from 1179S/05..*

PAGE NO	DESCRIPTION
2 – 1 TO 2 – 4	MAINFRAME ASSEMBLIES
3 – 1 TO 3 – 2	3 POINT LINKAGE KITS
4 – 1 TO 4 – 2	TANK ASSEMBLY
5 – 1 TO 5 – 2	KING POST & ROCKER
6 – 1 TO 6 – 4	ARM ASSEMBLIES
7 – 1 TO 7 – 2	COWL BRACKET AND LINKAGE
8 – 1 TO 8 – 5	TWIN PUMPS & GEARBOX ASSEMBLIES
9 – 1 TO 9 – 8	CONTROL VALVE ASSEMBLIES
10 – 1 TO 10 – 6	CONTROL ASSEMBLIES
11 – 1 TO 11 – 4	RAM CIRCUITS
12 – 1 TO 12 – 4	HOSE CIRCUITS
13 – 1 TO 13 – 2	OIL COOLER ASSEMBLY
14 – 1 TO 14 – 2	DECALS

#### IMPORTANT

THIS MACHINE IS FOR VEGETATION CONTROL AND MUST NOT BE USED FOR ANY OTHER  
PURPOSE.

IT IS POTENTIALLY HAZARDOUS TO FIT OR USE ANY PARTS OTHER THAN GENUINE  
BOMFORD TURNER PARTS.

THE COMPANY DISCLAIMS ALL LIABILITY FOR THE CONSEQUENCES OF SUCH USE  
WHICH, IN ADDITION, VOIDS THE MACHINE WARRANTY.

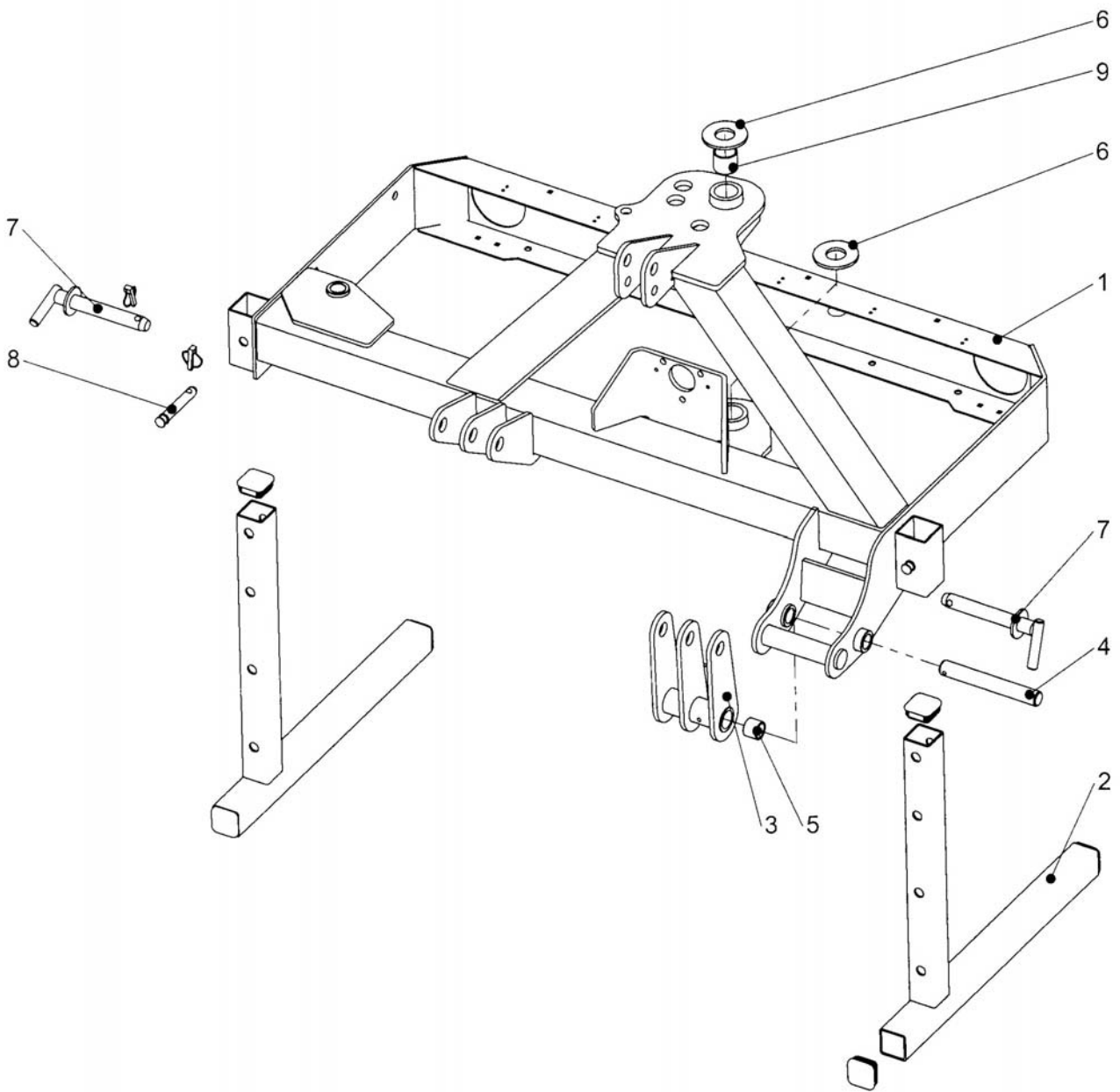

REF	PART NO	DESCRIPTION	QTY
77.314.01		MAINFRAME ASSY 70L HARRIER PAR	
*01	46875.03	HARRIER MAINFRAME 70L MAN SLEW	1
01	05.227.01	HAMMER DRIVE SCREW NO.6X3/8"	2
01	05.774.07	SERIAL NO. PLATE BOMFORDTURNER	1
01	9293054	BOLT CUP SQUARE M8X25	4
*02	46463.01	STAND ASSEMBLY	2
02	7191108	PLASTIC BUNG	6
03	42118.01	LINK - BREAKOUT LH	1
*04	03.654.75	PIN 30DIA X 224	1
04	05.287.01	SELF-LOCKING NUT M8	1
04	05.291.06	BOLT M8 X 55MM	1
05	08.297.04	BUSH - PLASTIC 37 X 30 X 30	2
06	09.232.01	THRUST WASHER	2
*07	07.574.01	PIN 1.1/8"DIA X 172	2
07	00.372.01	LINCH PIN	2
*08	T1657	PIN LINKAGE 3/4IN	2
08	00.372.01	LINCH PIN	2
09	08.297.02	BUSH – PLASTIC 47 X 40 X 40	2

\*MAIN PART IN GROUP, RELATED PARTS HAVE SAME REFERENCE NUMBER

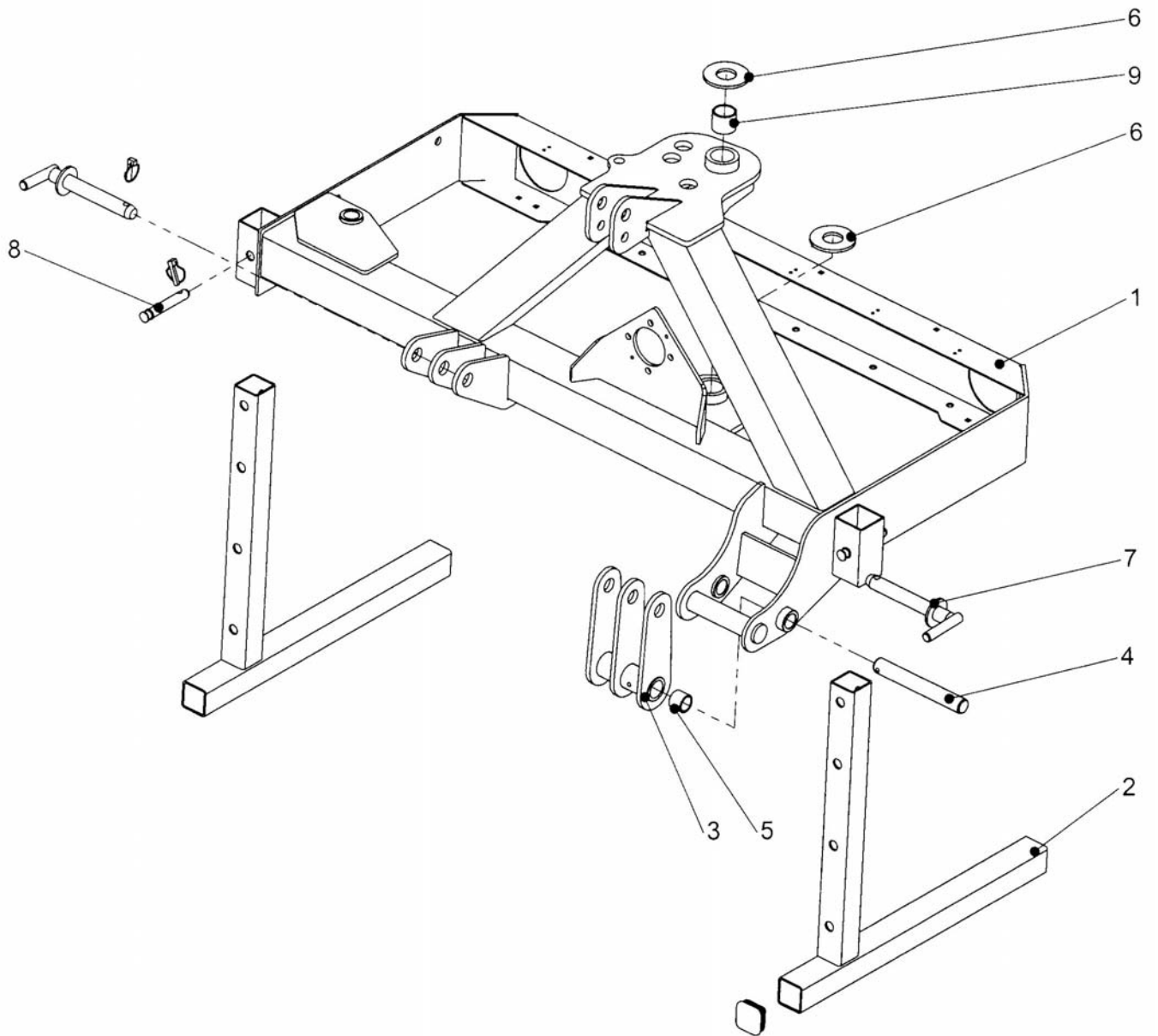

REF	PART NO	DESCRIPTION	QTY
77.302.01		MAINFRAME ASSY 84L HARRIER PAR	
*01	46875.01	HARRIER MAINFRAME 84L MAN SLEW	1
01	05.227.01	HAMMER DRIVE SCREW NO.6X3/8"	2
01	05.774.07	SERIAL NO. PLATE BOMFORDTURNER	1
01	9293054	BOLT CUP SQUARE M8X25	4
*02	46463.01	STAND ASSEMBLY	2
02	7191108	PLASTIC BUNG	6
03	42118.01	LINK - BREAKOUT LH	1
*04	03.654.75	PIN 30DIA X 224	1
04	05.287.01	SELF-LOCKING NUT M8	1
04	05.291.06	BOLT M8 X 55MM	1
05	08.297.04	BUSH - PLASTIC 37 X 30 X 30	2
06	09.232.01	THRUST WASHER	2
*07	07.574.01	PIN 1.1/8"DIA X 172	2
07	00.372.01	LINCH PIN	2
*08	T1657	PIN LINKAGE 3/4IN	2
08	00.372.01	LINCH PIN	2
09	08.297.02	BUSH – PLASTIC 47 X 40 X 40	2

\*MAIN PART IN GROUP, RELATED PARTS HAVE SAME REFERENCE NUMBER

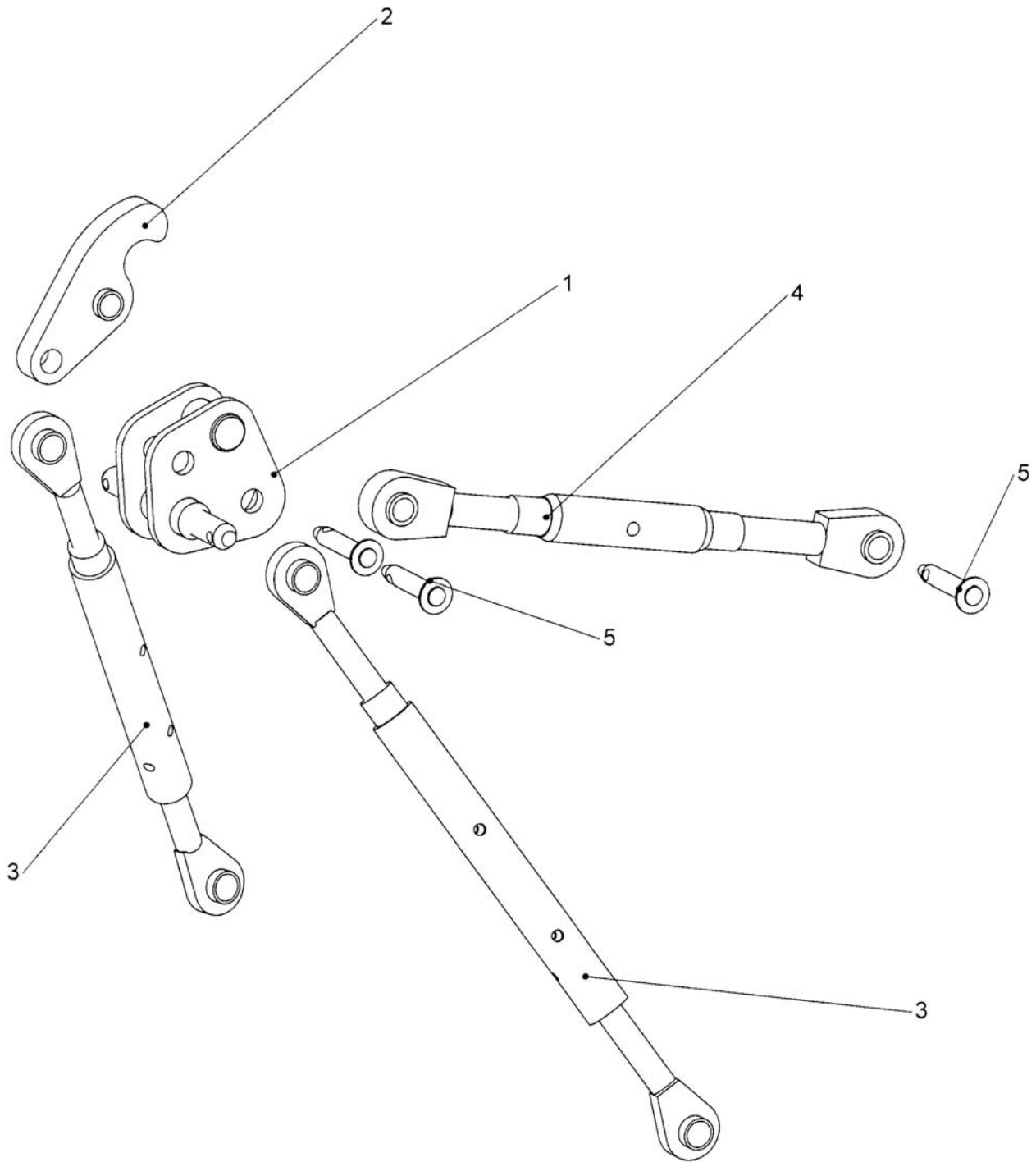



<b>REF</b>	<b>PART NO</b>	<b>DESCRIPTION</b>	<b>QTY</b>
77.310.01	TUBULAR STABILISERS		
01	46940.01	TOP LINK YOKE STABILISERS	1
02	46940.02	TOP LINK BRKT STABILISERS	1
03	46938.01	STABILISER LINK S.75220	2
04	07.584.02	TOP LINK - HEAVY DUTY	1
05	03.873.01	PIN 1"DIA X 140	3
05	00.372.01	LINCH PIN	3

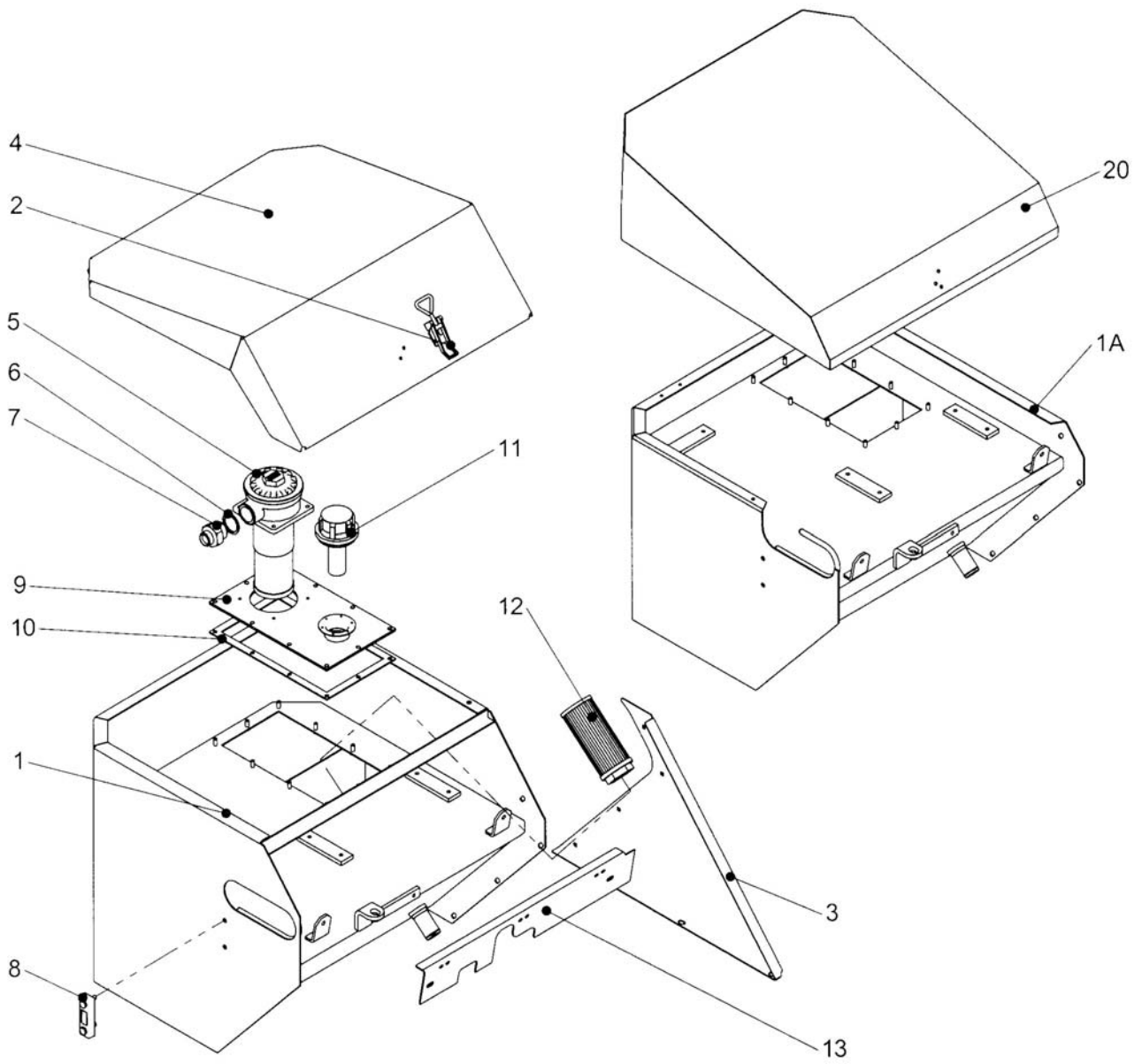

REF	PART NO	DESCRIPTION	QTY
77.305.01/02 OIL TANK ASSY – HARRIER LH/RH 84LTR			
77.360.01/02 OIL TANK ASSY – HARRIER LH/RH 70LTR			
*01	46911.01▶	TANK - LH	1
01	46911.02▶	TANK - RH	1
01A	46911.03◀	TANK - LH	1
01A	46911.04◀	TANK - RH	1
01	04.282.88	STUD M10 X 23	4
01	03.100.01	STUD M10 X 34MM	6
01	05.863.02	JUBILEE CLIP 2"DIA	1
01	05.863.03	JUBILEE CLIP 20-32 DIA	1
01	05.963.01	POP RIVET 4.8MM DIA X 7.6MM	2
01	05.264.13	SETSCREW M10 X 30MM PLATED	1
01	05.286.02	NUT M10 PLATED	3
01	05.281.02	FLT WASHER 10MM PLATED FORM	2
01	05.287.02	SELF-LOCKING NUT M10 PLATED	2
01	05.287.04	SELF-LOCKING NUT M16 PLATED	3
01	05.291.35	BOLT M16 X 50MM PLATED	3
01	05.264.01	SETSCREW M8 X 20MM PLATED	4
01	05.282.01	SPRING WASHER 8MM PLATED	4
01	46065.01◀	HINGE	2
02	43449.04	FASTENER - OVERCENTRE	1
*03	46229.01	GUARD - REAR LH 2MM	1
03	46229.02	GUARD - REAR RH 2MM	1
03	9293054	BOLT CUP SQUARE M8X25	7
03	05.287.01	SELF-LOCKING NUT M8 PLATED	7
03	05.281.01	FLAT WASHER 8MM PLATED	7
*04	46282.01▶	COVER - TANK HARRIER	1
04	46295.01▶	PIN – PIVOT	1
05	46750.01	FILTER ASSEMBLY 125L PARKER	1
06	05.290.08	BONDED SEAL 1.¼" BSP	1
07	05.131.01▲	ADAPTOR 1" X 1.¼" BSP	1
07	42627.01▼	ADAPTOR ¾" X 1¼" BSP	1
08	08.921.01	FLUID LEVEL GAUGE	1
*09	41.255.01	PLATE - FILLER/FILTER	1
09	05.281.01	FLAT WASHER 8MM PLATED	10
09	05.286.01	NUT M8 PLATED	10
10	08.605.01	GASKET	1
11	06.966.02	FILLER BREATHER CAP & STRAINER	1
12	8401047	SUCTION ELEMENT	1
13	47146.01▶	FRONT PLATE LH	1
13	47146.02▶	FRONT PLATE RH	1
13	47333.03◀	FRONT PLATE LH	1
13	47333.04◀	FRONT PLATE RH	1

## 77.410.01 OIL TANK COVER #

20	45225.10◀	TANK COVER	1
----	-----------	------------	---

# For machines with oil coolers see Page 13 -1 &amp; 13 - 2

▲ 84 LTR MACHINES

▼ 70 LTR MACHINES

▶ Up to Serial No. 3059S/095

◀ From Serial No. 3060S/05

\*MAIN PART IN GROUP, RELATED PARTS HAVE SAME REFERENCE NUMBER

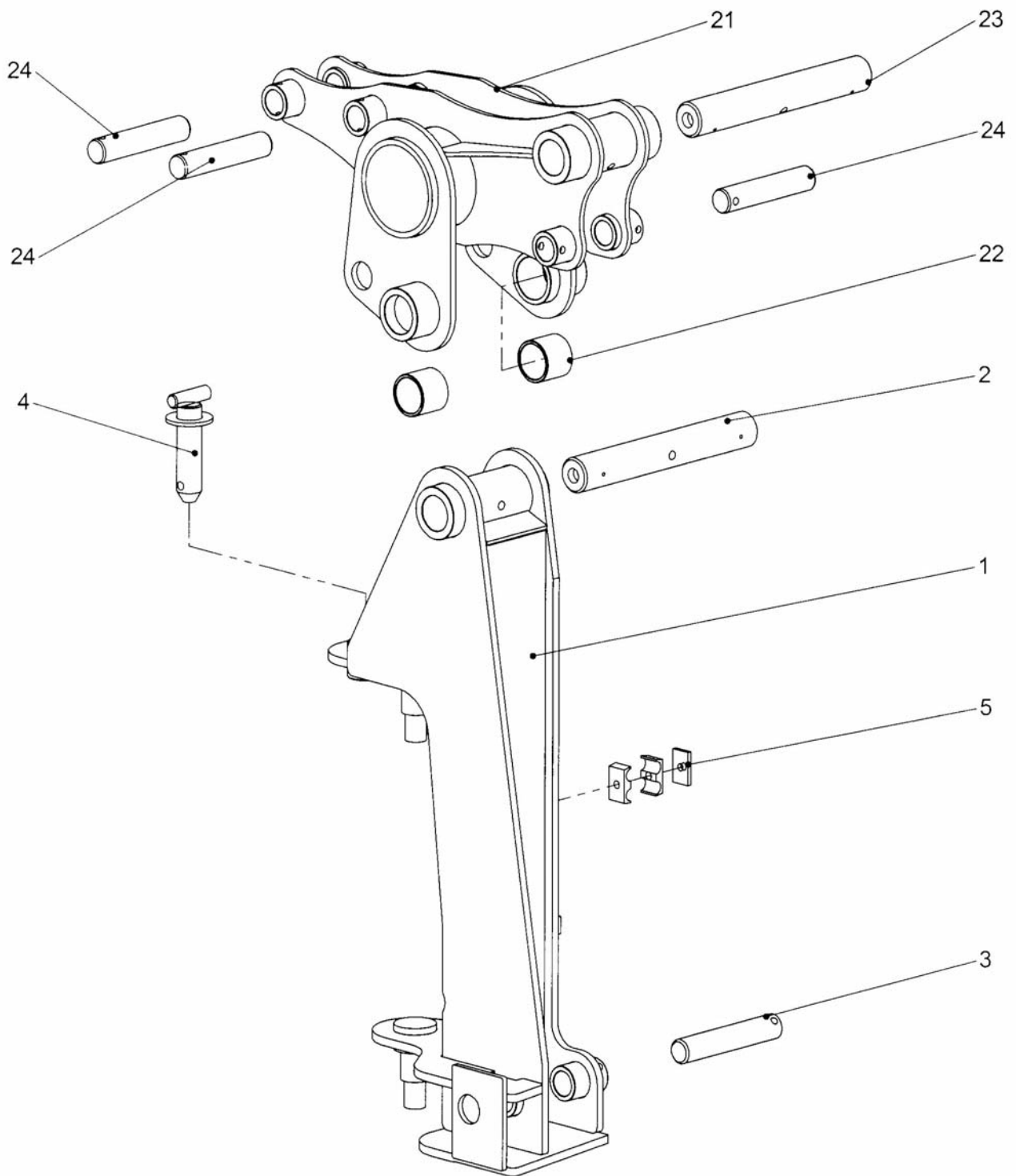

REF	PART NO	DESCRIPTION	QTY
77.301.01	KINGPOST PAR ASSY LH HARRIER		
01*	46876.03	KINGPOST	1
01	05.962.07	FLAT WASHER	2
01	05.287.07	SELF-LOCKING NUT M30	2
*02	03.657.24	PIN - DIA 50 X 341	1
02	05.953.01	GREASE NIPPLE M6	2
02	05.291.18	BOLT M10 X 65 PLATED	1
02	05.287.02	SELF-LOCKING NUT M10 PLATED	1
*03	03.655.53	PIN 35 X 189	1
03	05.291.05	BOLT M8 X 50 MM PLATED	1
03	05.287.01	SELF-LOCKING NUT M8 PLATED	1
04	46923.01	PIN 35 DIA	1
05	04.282.66	STUD - M10 X 56	1
05	05.282.02	SPRING WASHER 10MM PLATED	1
05	05.286.02	NUT M10 PLATED	1
05	06.418.06	CLAMP PLATE 48 X 6	1
*05	06.430.02	CLAMP HOSE	2
77.307.01	ROCKER ASSY HARRIER		
21	46914.01	BRACKET - ROCKER	1
22	08.297.01	BUSH - PLASTIC 60 X 50 X 50	2
*23	03.657.24	PIN - DIA 50 X 341	1
23	05.287.03	SELF-LOCKING NUT M12 PLATED	2
23	05.292.22	BOLT M12 X 90MM PLATED	2
23	05.953.01	GREASE NIPPLE M6	2
*24	03.655.33	PIN - DIA 35 X 172	3
24	05.287.02	SELF-LOCKING NUT M10 PLATED	3
24	05.291.18	BOLT M10 X 65 PLATED	3

\*MAIN PART IN GROUP, RELATED PARTS HAVE SAME REFERENCE NUMBER

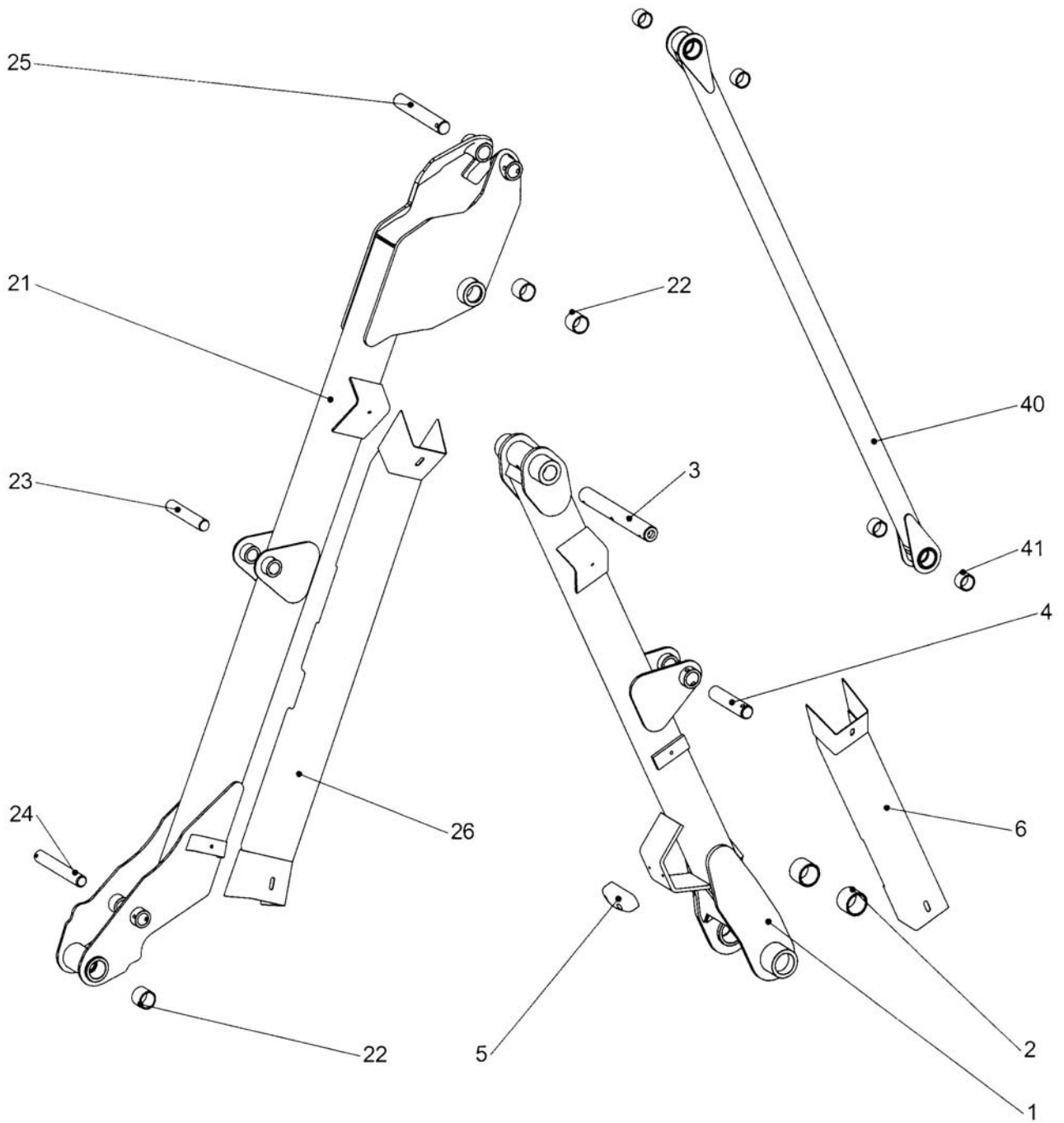

REF	PART NO	DESCRIPTION	QTY
77.311.01	FIRST ARM ASSY-HARRIER 4.7 PAR		
*01	46950.01	FIRST ARM HARRIER 4.7 PARA	1
01	04.282.10	STUD M10 X 100MM	1
01	04.282.84	STUD M10 X 1.5 - 95 LONG	2
01	05.282.02	SPRING WASHER 10MM PLATED	3
01	9100025	NUT DOMED M10 PLATED	3
02	08.297.01	BUSH - PLASTIC 60 X 50 X 50	2
*03	43292.02	PIN 40 DIA X 328	1
03	05.287.02	SELF-LOCKING NUT M10 PLATED	1
03	05.292.11	BOLT M10 X 80MM PLATED	1
*04	03.655.69	PIN 35 DIA 166MM	1
04	05.287.02	SELF-LOCKING NUT M10 PLATED	1
04	05.291.18	BOLT M10 X 65 PLATED	1
*05	46237.01	RUBBER BUFFER	1
05	05.625.37	SOCKET CAPSCREW M8 X 30	2
06	47103.01	HOSE GUARD	1
77.312.01	SECOND ARM ASSY-HARRIER 4.7PAR		
*21	46953.01	SECOND ARM HARRIER 4.7 PAR	1
21	05.953.04	GREASE NIPPLE M10 90 DEG	1
21	04.282.84	STUD M10 X 1.5 - 95 LONG	2
21	05.282.02	SPRING WASHER 10MM PLATED	2
21	9100025	NUT DOMED M10 PLATED	2
21	05.953.01	GREASE NIPPLE M6	2
22	08.297.02	BUSH - PLASTIC 47 X 40 X 40	4
*23	03.654.89	PIN 30 DIA X 170	1
23	05.292.11	BOLT M10 X 80MM PLATED	1
23	05.287.02	SELF-LOCKING NUT M10 PLATED	1
*24	03.654.79	PIN - DIA 30 X 214	1
24	05.291.18	BOLT M10 X 65 PLATED	1
24	05.287.02	SELF-LOCKING NUT M10 PLATED	1
*25	03.655.68	PIN 35DIA - 226PLATED	1
25	05.291.06	BOLT M8 X 55MM PLATED	2
25	05.287.01	SELF-LOCKING NUT M8 PLATED	2
26	47102.01	HOSE GUARD	1
77.313.01	LINK ASSY - HARRIER 4.7 PAR		
*40	46952.01	LINK HARRIER 4.7 PAR	1
40	05.953.03	GREASE NIPPLE M10	2
41	08.297.05	PLASTIC BUSH - 42 X 35 - 30	4

\*MAIN PART IN GROUP, RELATED PARTS HAVE SAME REFERENCE NUMBER

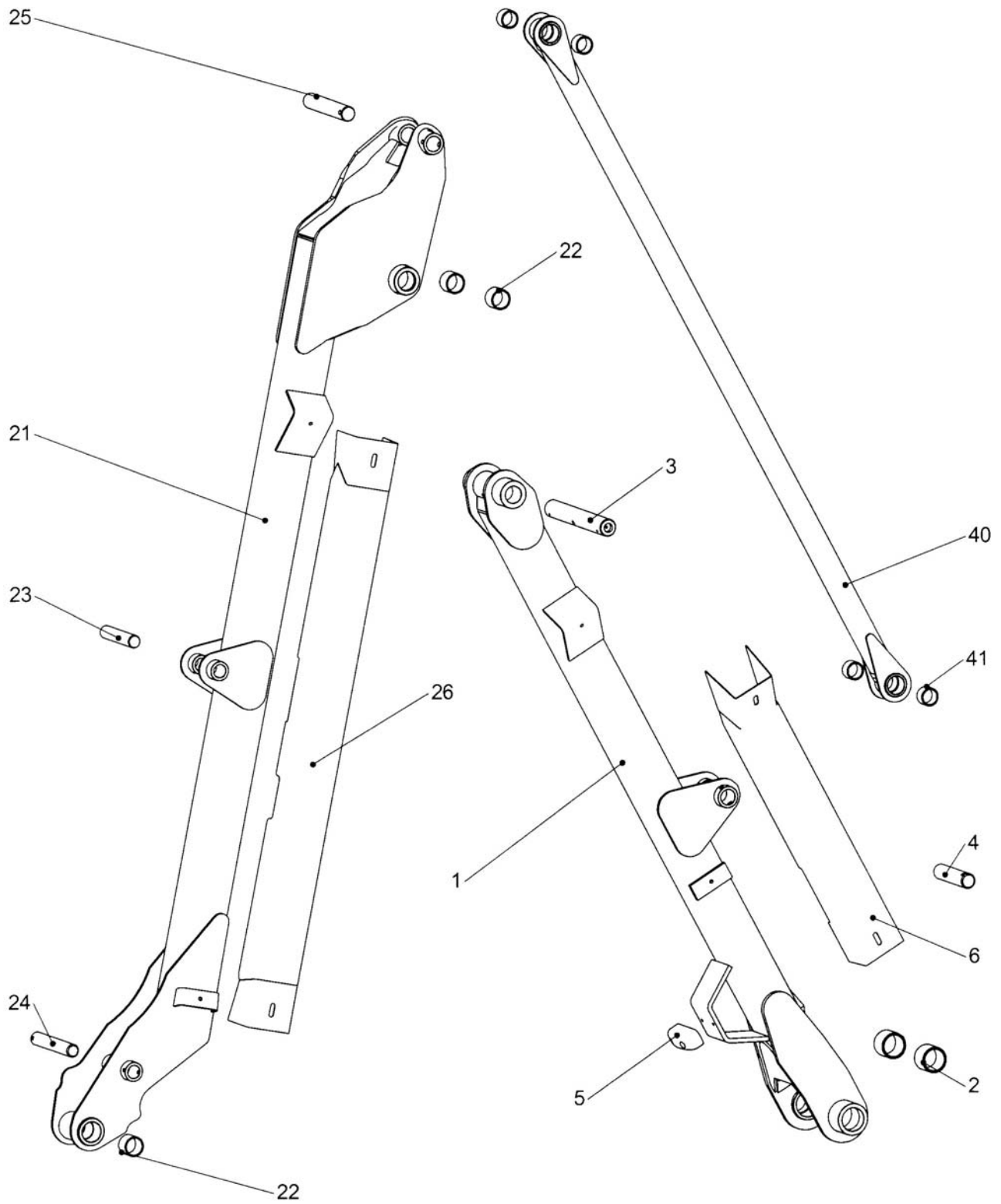



REF	PART NO	DESCRIPTION	QTY
77.318.01	FIRST ARM ASSY-HARRIER 5.0 PAR		
*01	46961.01	FIRST ARM HARRIER 5.0 PARA	1
01	04.282.10	STUD M10 X 100MM	1
01	04.282.84	STUD M10 X 1.5 - 95 LONG	2
01	05.282.02	SPRING WASHER 10MM PLATED	3
01	9100025	NUT DOMED M10 PLATED	3
02	08.297.01	BUSH - PLASTIC 60 X 50 X 50	2
*03	43292.02	PIN 40 DIA X 328	1
03	05.287.02	SELF-LOCKING NUT M10 PLATED	1
03	05.292.11	BOLT M10 X 80MM PLATED	1
*04	03.655.69	PIN 35 DIA 166MM	1
04	05.287.02	SELF-LOCKING NUT M10 PLATED	1
04	05.291.18	BOLT M10 X 65 PLATED	1
05	05.625.37	SOCKET CAPSCREW M8 X 30	2
05	46237.01	RUBBER BUFFER	1
06	47054.02	HOSE GUARD	1
77.316.01	SECOND ARM ASSY-HARRIER 5.0PAR		
*21	46962.01	SECOND ARM HARRIER 5.0 PAR	1
21	05.953.04	GREASE NIPPLE M10 90 DEG	1
21	04.282.84	STUD M10 X 1.5 - 95 LONG	2
21	05.282.02	SPRING WASHER 10MM PLATED	2
21	9100025	NUT DOMED M10 PLATED	2
21	05.953.01	GREASE NIPPLE M6	2
22	08.297.02	BUSH - PLASTIC 47 X 40 X 40	4
*23	03.654.89	PIN 30 DIA X 170	1
23	05.292.11	BOLT M10 X 80MM PLATED	1
23	05.287.02	SELF-LOCKING NUT M10 PLATED	1
*24	03.654.79	PIN - DIA 30 X 214	1
24	05.291.18	BOLT M10 X 65 PLATED	1
24	05.287.02	SELF-LOCKING NUT M10 PLATED	1
*25	03.655.68	PIN 35DIA - 226PLATED	1
25	05.291.06	BOLT M8 X 55MM PLATED	2
25	05.287.01	SELF-LOCKING NUT M8 PLATED	2
26	47056.01	HOSE GUARD	1
77.317.01	LINK ASSY - HARRIER 5.0 PAR		
*40	46963.01	LINK HARRIER 5.0 PAR	1
40	05.953.03	GREASE NIPPLE M10	2
41	08.297.05	PLASTIC BUSH - 42 X 35 - 30	4

\*MAIN PART IN GROUP, RELATED PARTS HAVE SAME REFERENCE NUMBER

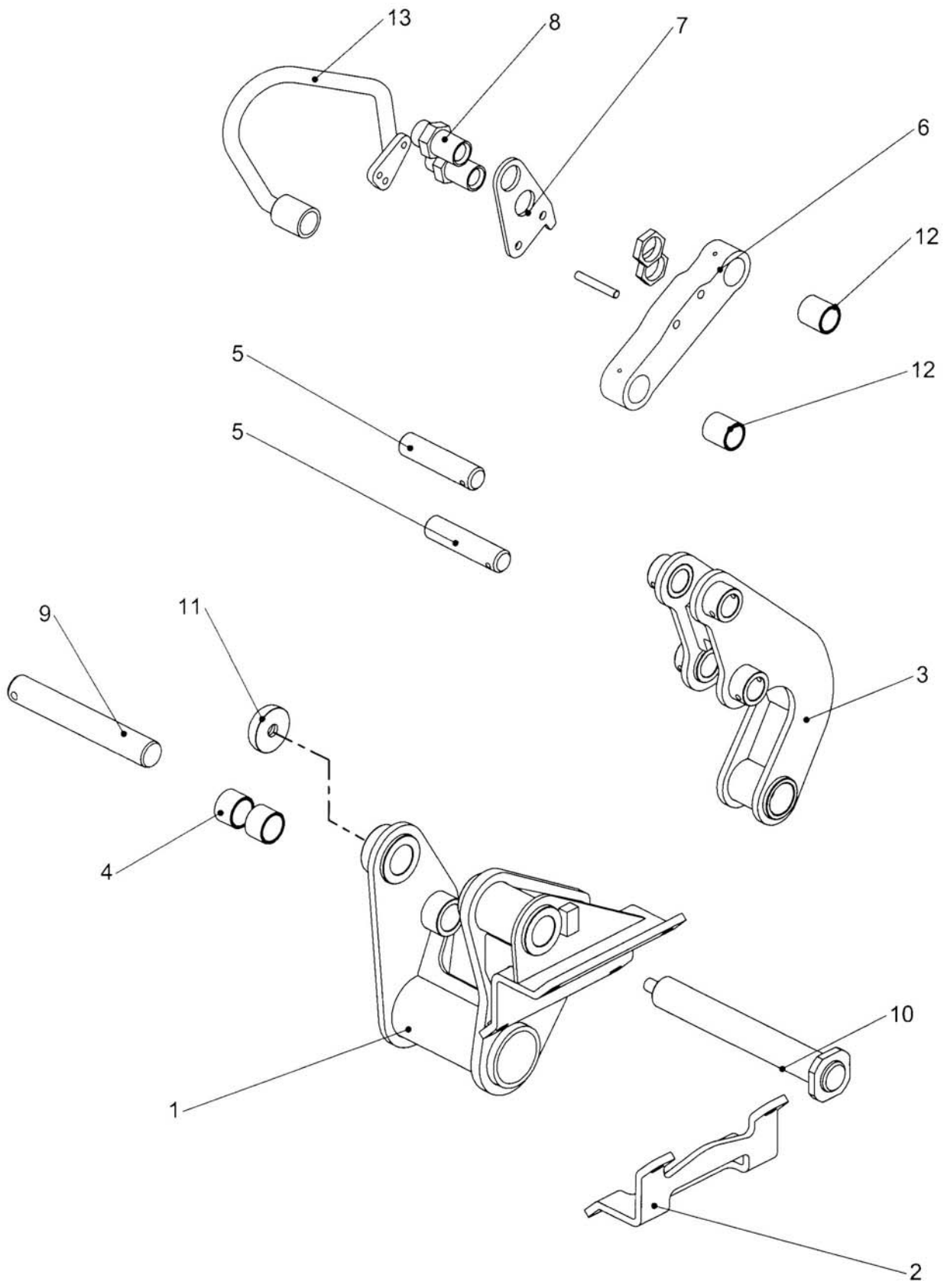

REF	PART NO	DESCRIPTION	QTY
77.339.01/02 HEAD ANGLING BRKT ASSY 70 LTR			
77.182.01/02 HEAD ANGLING BRKT ASSY 84 LTR			
1	46250.01	BRACKET HEAD ANGLING LH	1
1	46250.02	BRACKET HEAD ANGLING RH	1
2	05.264.36	SETSCREW M16 X 45MM PLATED	4
2	05.282.04	SPRING WASHER 16MM PLATED	5
2	05.286.04	NUT M16 PLATED	5
*2	46273.01	CLAMP	1
3	45950.01	LINK	1
3	05.953.03	GREASE NIPPLE M10	1
4	08.297.05	PLASTIC BUSH - 42 X 35 - 30	2
*5	03.654.59	PIN - DIA 30 X 128	2
5	05.287.01	SELF-LOCKING NUT M8 PLATED	2
5	05.291.06	BOLT M8 X 55MM PLATED	2
6	05.953.01	GREASE NIPPLE M6	1
6	05.953.05	GREASE NIPPLE M6 X 90DEG	1
*6	46090.01	LINK	1
▲7	45491.01	PLATE - BULKHEAD - 6MM PLT	1
▼7	45491.04	PLATE - BULKHEAD - 6MM PLT	1
▲8	08.128.03	ADAPTOR 1" BSP BULKHEAD C/W L NUT	2
▼8	08.128.08	ADAPTOR ¾" BSP BULKHEAD C/W L NUT	2
*9	03.655.63	PIN 35 DIA X 240	1
9	05.287.02	SELF-LOCKING NUT M10 PLATED	3
9	05.291.18	BOLT M10 X 65 PLATED	1
10	05.282.04	SPRING WASHER 16MM PLATED	5
10	05.286.04	NUT M16 PLATED	5
*10	46251.01	PIN BRKT PIVOT 40 DIA	1
11	07.942.03	WASHER - SPECIAL M16	1
12	08.297.10	PLASTIC BUSH - 37 X 30 - 40	2
*13	45954.01	GUARD - BULKHEAD	1
13	04.282.76	STUD - M10 X 70 PLATED	2
13	05.291.18	BOLT M10 X 65 PLATED	1

▲ 84 LTR MACHINES

▼ 70 LTR MACHINES

\*MAIN PART IN GROUP, RELATED PARTS HAVE SAME REFERENCE NUMBER

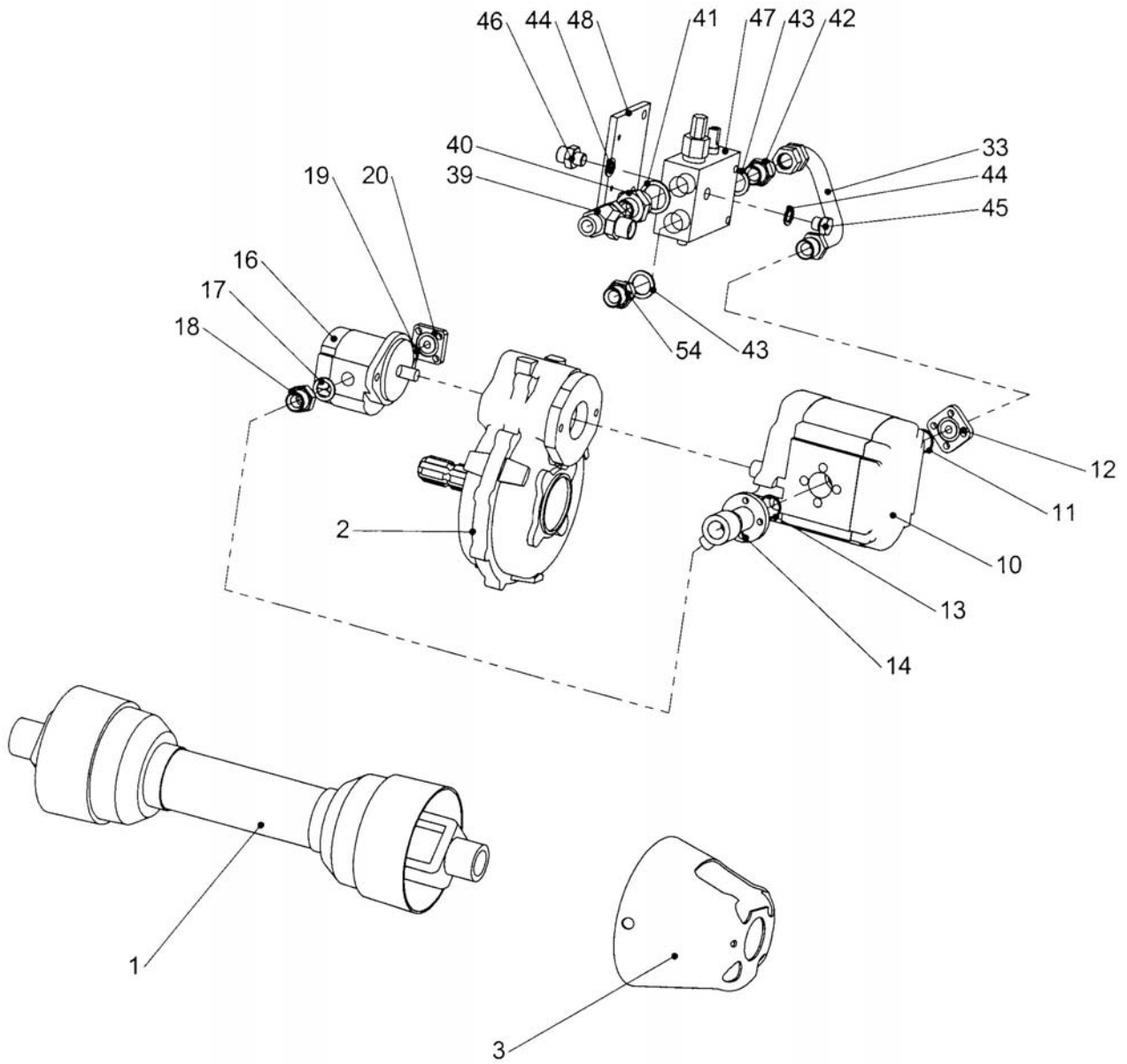

REF	PART NO	DESCRIPTION	QTY
<b>76.467.01 PTO/GEARBOX ASSY</b>			
01*	41623.02	PTO SHAFT ASSY 610MM C/C	1
01	41623.31	CROSS JOURNAL SET	0
01	41623.33	COMPLETE SHIELD	0
02*	09.828.01	GEARBOX ASSY - ESII	1
02	04.174.01	STUD M12 X 38MM	3
02	05.968.03	SELF LOCKING NUT M12 (FINE)	3
03*	42273.02	PTO CUP GUARD	1
03	05.281.01	FLAT WASHER 8MM PLATED	2
03	05.282.01	SPRING WASHER 8MM PLATED	2
03	05.839.03	SETSCREW M8 X 16MM PLATED	2

**76.474.01 PUMP ASSEMBLIES**

10	05.650.05	PUMP	1
11	05.656.03	"O"RING 25 I/D X 3.53	1
12*	03.864.01	ADAPTOR-FLANGED 3/4"BSP PLATED	1
12	05.657.01	SCKT CAPSCRW 5/16"UNCX7/8" PLT	4
13	05.656.01	"O"RING 28 I/D X 2.5	1
14	05.657.01	SCKT CAPSCRW 5/16"UNCX7/8" PLT	4
14*	06.251.01	ADAPTOR - INLET	1
15*	03.100.01	STUD M10 X 34MM	2
15	05.282.02	SPRING WASHER 10MM PLATED	2
15	05.286.02	NUT M10 PLATED	2
16	09.537.01	GEAR PUMP	1
17	05.290.05	BONDED SEAL 1/2"BSP	1
18	05.376.01	ADAPTOR 1/2"BSP X 3/4"O/D	1
19	30.210.92	O RING 200-121-4490	1
20	05.657.01	SCKT CAPSCRW 5/16"UNCX7/8" PLT	4
20*	09.745.01	ADAPTOR-FLANGE 3/8"BSP PLATED	1
21	05.282.02	SPRING WASHER 10MM PLATED	2
21	05.286.02	NUT M10 PLATED	2
21*	05.291.13	BOLT M10 X 40MM PLATED	2

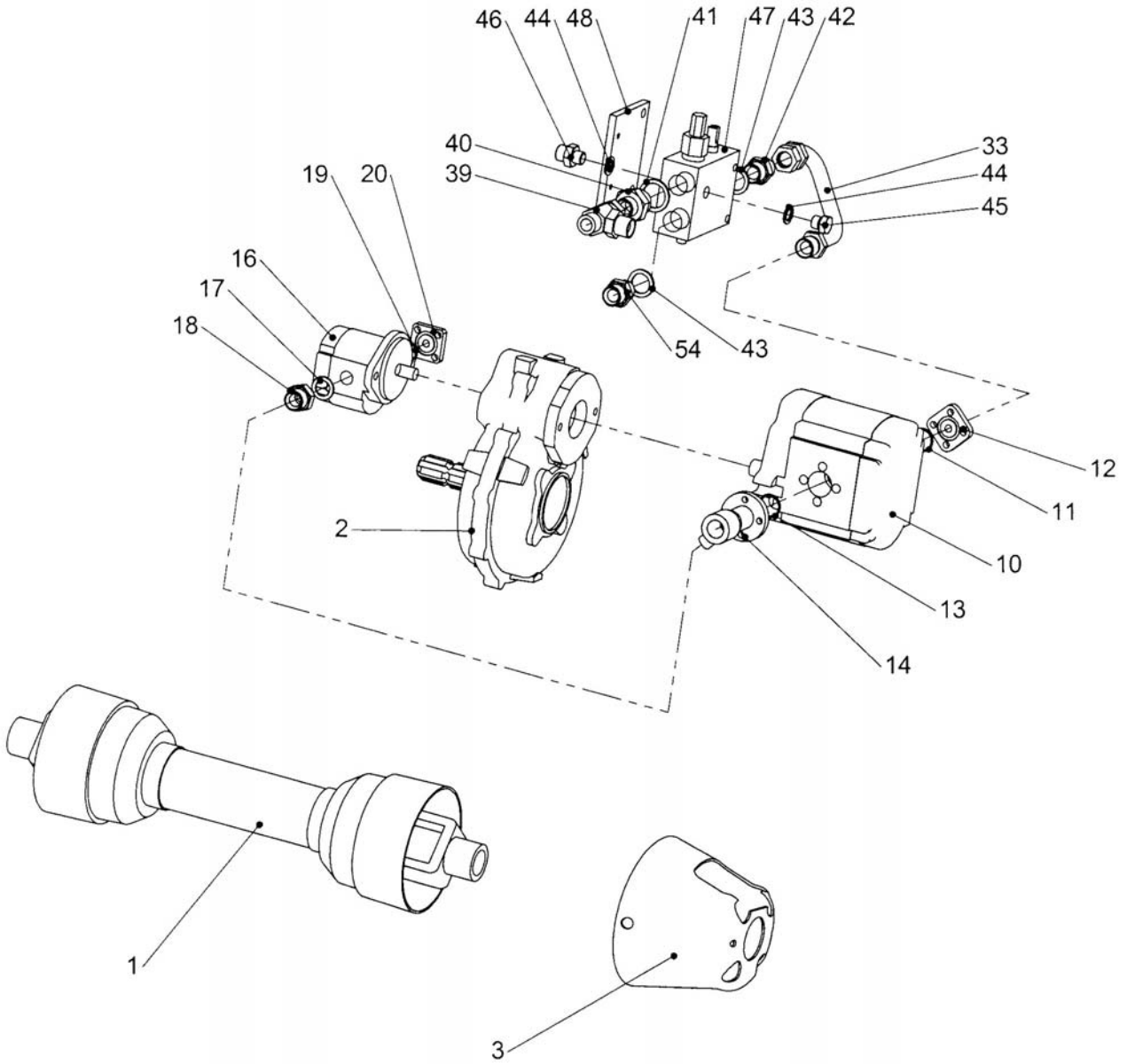

REF	PART NO	DESCRIPTION	QTY
<b>76.350.01 PUMP CIRCUIT 70LT TWIN LH</b>			
31	05.863.02	JUBILEE CLIP 2"DIA - NI	3
39	04.056.01	ADAPTOR-SWIVEL TEE 3/4"BSP F/M/M	1
40	05.373.01	ADAPTOR 3/4"BSP X 1"BSP	1
41	05.290.07	BONDED SEAL 1"BSP	1
42	05.277.01	ADAPTOR 3/4"BSP X 3/4"BSP	1
43	05.290.06	BONDED SEAL 3/4"BSP	2
44	05.290.04	BONDED SEAL 3/8"BSP	2
45	05.433.01	PLUG 3/8"BSP PLATED	1
46	05.123.01	ADAPTOR 1/2" BSP X 3/8" BSP	1
*47	06.284.16	DIVERTER/RELIEF ASSY - 207 BAR	1
47	05.282.01	SPRING WASHER 8MM PLATED	2
47	05.291.07	BOLT M8 X 60MM PLATED	2
47	06.284.02	SEAL KIT FOR (06.284.01) VALVE	-
47	06.299.03	RELIEF VALVE CARTRIDGE 207BAR	-
*48	46058.01	PLATE - VALVE MOUNTING	1
48	05.264.02	SETSCREW M8 X 25MM PLATED	2
48	05.287.01	SELF-LOCKING NUT M8 PLATED	2
50	05.863.03	JUBILEE CLIP 20-32 DIA - NI	1
54	05.377.01	ADAPTOR 3/4"BSP X 3/4"BSP	1
55	05.313.01	PLUG 3/4" BSP (MOTOR HOSES) – N.I.	2
56	05.835.01	ADAPTOR SWIVEL 90 – 3/8" BSP	1

N.I. NOT ILLUSTRATED

\*MAIN PART IN GROUP, RELATED PARTS HAVE SAME REFERENCE NUMBER

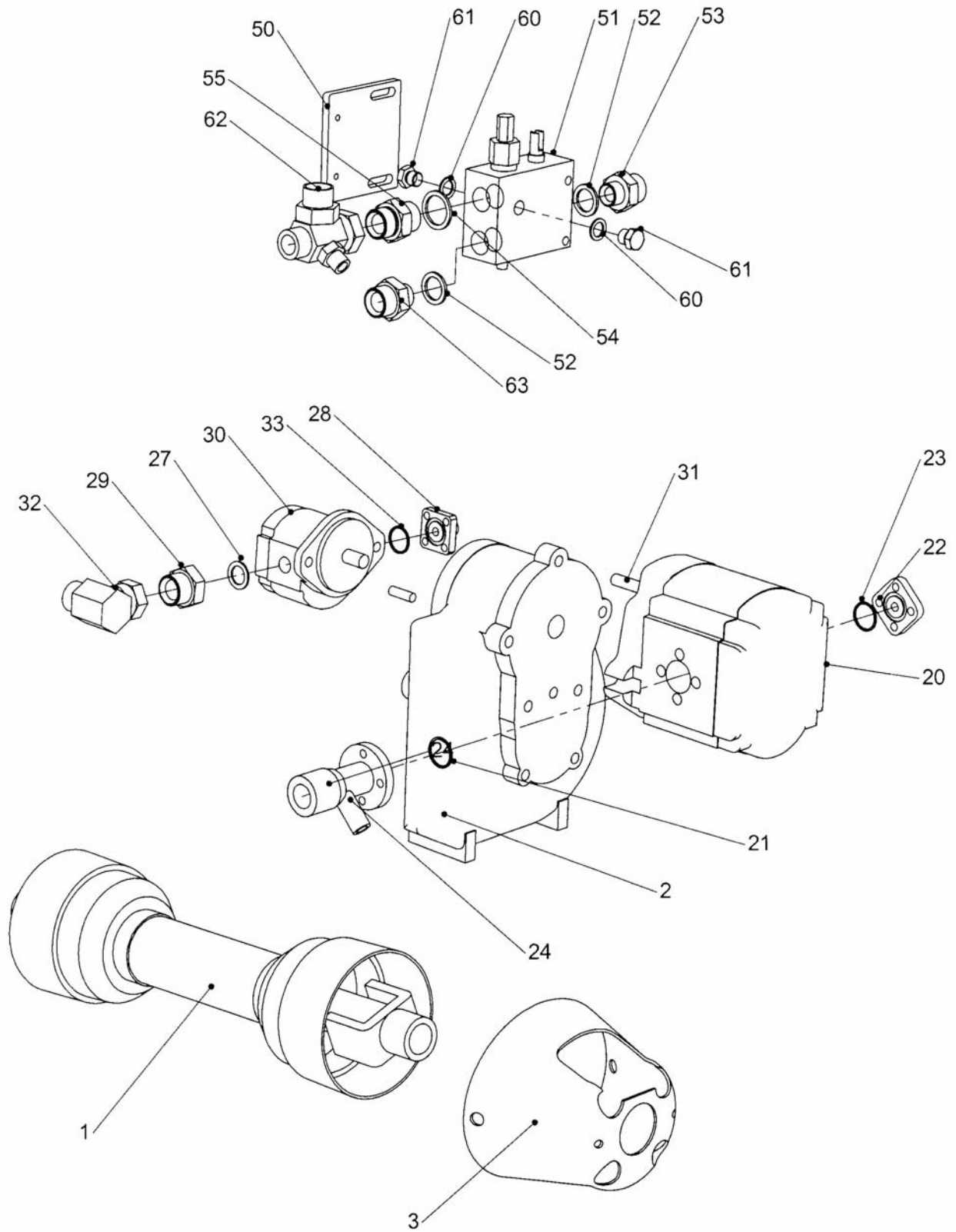



REF	PART NO	DESCRIPTION	QTY
<b>77.303.01 PTO/GEARBOX/PUMP CABLE</b>			
*01	41624.01	PTO SHAFT ASSY 560 MM C/C	1
01	41624.31	CROSS JOURNAL SET	0
01	41624.32	COMPLETE SHIELD	0
*02	42693.04	GEARBOX 3.6:1 CAST IRON	1
02	05.968.03	SELF LOCKING NUT M12 (FINE)	4
02	43548.32	STUD M12 FINE M12 COARSE	1
*03	08.548.01	GUARD - PLASTIC PTO CUP	1
03	05.281.01	FLAT WASHER 8MM PLATED	2
03	05.282.01	SPRING WASHER 8MM PLATED	2
03	05.839.03	SETSCREW M8 X 16MM PLATED	2
20	01.071.13	KEY-SEP 1/4"X1/4"X1"	0
20	05.642.02	SEAL KIT (05 650 PUMPS)	0
*20	05.650.05	PUMP	1
21	05.656.01	"O"RING 28 I/D X 2.5	1
*22	03.864.01	ADAPTOR-FLANGED 3/4"BSP PLATED	1
22	05.657.01	SCKT CAPSCRW 5/16"UNCX7/8" PLT	4
23	05.656.03	"O"RING 25 I/D X 3.53	1
24	05.657.01	SCKT CAPSCRW 5/16"UNCX7/8" PLT	4
*24	06.251.01	ADAPTOR - INLET	1
24	05.863.02	JUBILEE CLIP 2"DIA	2
24	05.863.03	JUBILEE CLIP 20-32 DIA	1
25	03.100.01	STUD M10 X 34MM	1
25	05.282.02	SPRING WASHER 10MM PLATED	1
25	05.286.02	NUT M10 PLATED	1
27	05.290.05	BONDED SEAL 1/2"BSP	1
28	09.745.01	ADAPTOR-FLANGE 3/8"BSP PLATED	1
29	30.059.84	ADAPTOR 1/2 BSPM / 1 BSPM	1
30	05.657.01	SCKT CAPSCRW 5/16"UNCX7/8" PLT	4
*30	09.537.21	GEAR PUMP 1PX070	1
31	03.100.01	STUD M10 X 34MM	1
31	03.100.02	STUD M10 X 32MM	2
31	05.283.02	SHAKEPROOF WASHER 10MM PLATED	2
31	9133005	M10 THIN PLAIN NUT	2
32	05.835.02	ADAPTOR-SWIVEL 90 1"BSP M/F	1
33	30.210.92	O RING 200-121-4490	1

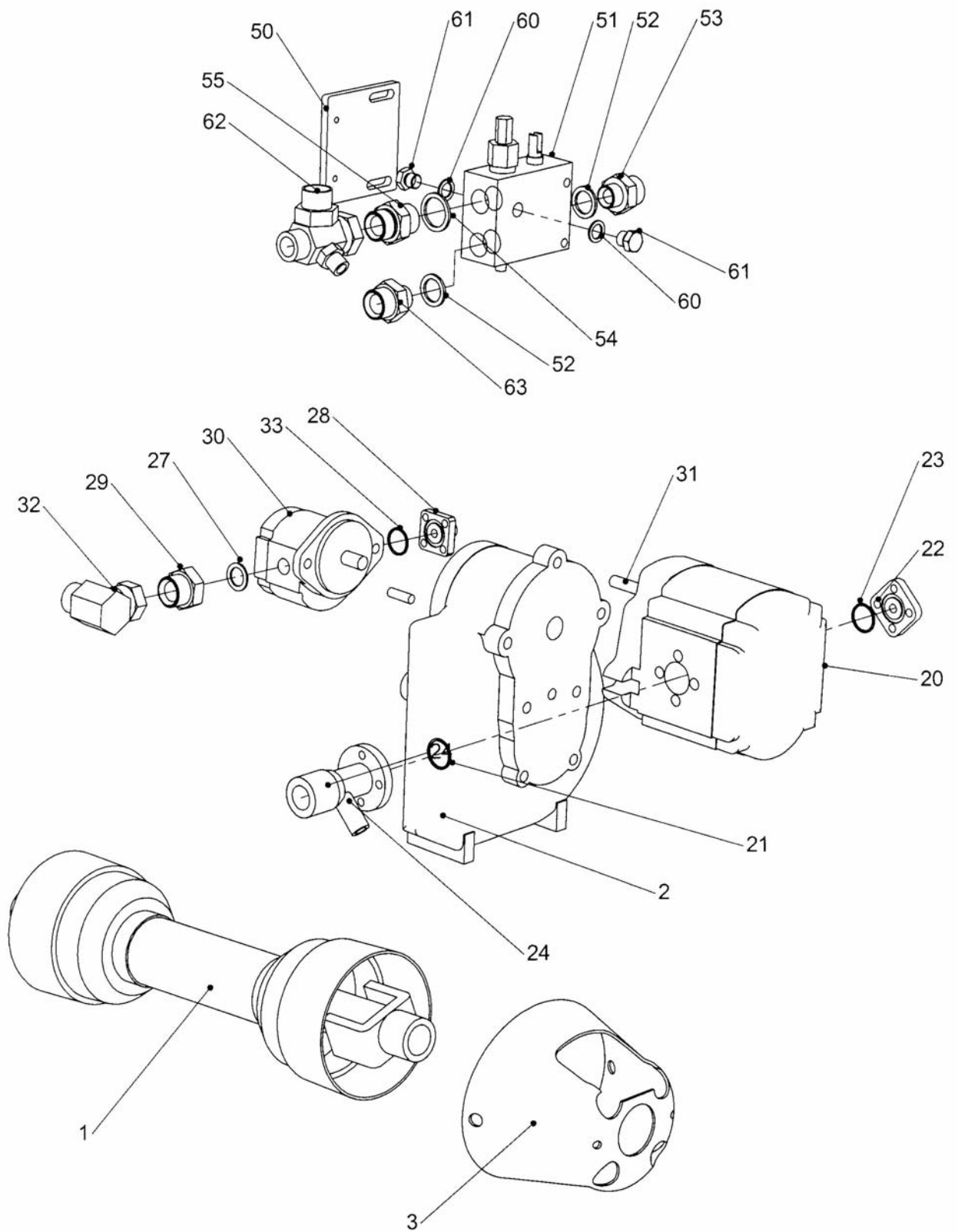

REF	PART NO	DESCRIPTION	QTY
<b>77.126.18 PUMP CIRCUIT CABLE</b>			
50	05.282.01	SPRING WASHER 8MM PLATED	2
50	05.291.07	BOLT M8 X 60MM PLATED	2
*50	46058.01	FLT 100 X 10 - 130	1
51	06.284.16	DIVERTER/RELIEF ASSY - 207 BAR	1
52	05.290.06	BONDED SEAL 3/4"BSP	2
53	05.373.01	ADAPTOR 3/4"BSP X 1"BSP	1
54	05.290.07	BONDED SEAL 1"BSP	1
55	05.434.01	ADAPTOR 1"BSP X 1"BSP	1
58	05.434.01	ADAPTOR 1"BSP X 1"BSP	2
59	05.433.03	PLUG 1"BSP PLATED	2
60	05.290.04	BONDED SEAL 3/8"BSP	2
61	05.433.01	PLUG 3/8"BSP PLATED	2
62	04.056.46	ADAPTOR-SPECIAL M/M/M/F	1
63	05.373.01	ADAPTOR 3/4" BSP X 1" BSP	1

\*MAIN PART IN GROUP, RELATED PARTS HAVE SAME REFERENCE NUMBER

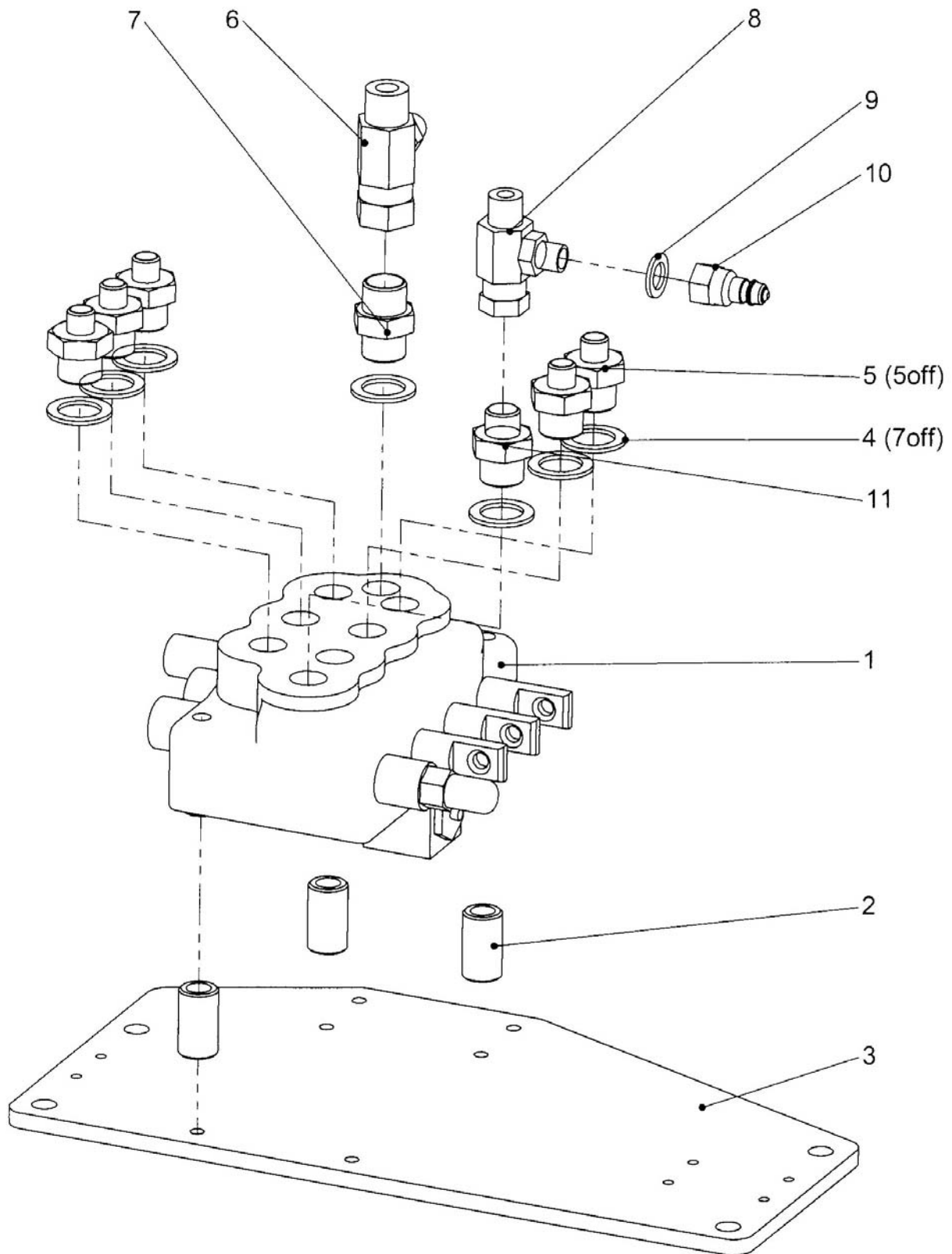

REF	PART NO	DESCRIPTION	QTY
<b>77.304.01</b>	<b>CONTROL VALVE ASSY 3 SERV</b>		
*01	46924.15	VALVE 3 SERVICE CABLE	1
01	05.281.02	FLT WASHER 10MM PLATED	3
01	05.282.01	SPRING WASHER 8MM	3
01	05.292.02	BOLT M8 X 90MM PLATED	3
02	46924.31	SPACER 3/4" X 33MM	3
*03	46924.32	VALVE MTG PLATE 8MM	1
03	9343032	M5 X 16 SKT.HD. CAPSCREW	6
04	05.290.05	BONDED SEAL 1/2"BSP	7
05	01.099.03	ADAPTOR 1/2BSP X 1/4BSP	5
06	04.056.25	ADAPTOR T FMM 1/2"X1/2"X1/4"	1
07	05.122.01	ADAPTOR 1/2" BSP X 1/2" BSP	1
08	04.056.16	ADAPTOR F/M/M 3/8X3/8X1/4 BSP	1
09	05.290.02	BONDED SEAL 1/4"BSP	1
10	05.146.12	Q/R COUPLING 1/4" BSP MALE	1
11	05.123.01	ADAPTOR 1/2" BSP X 3/8" BSP	1

\*MAIN PART IN GROUP, RELATED PARTS HAVE SAME REFERENCE NUMBER

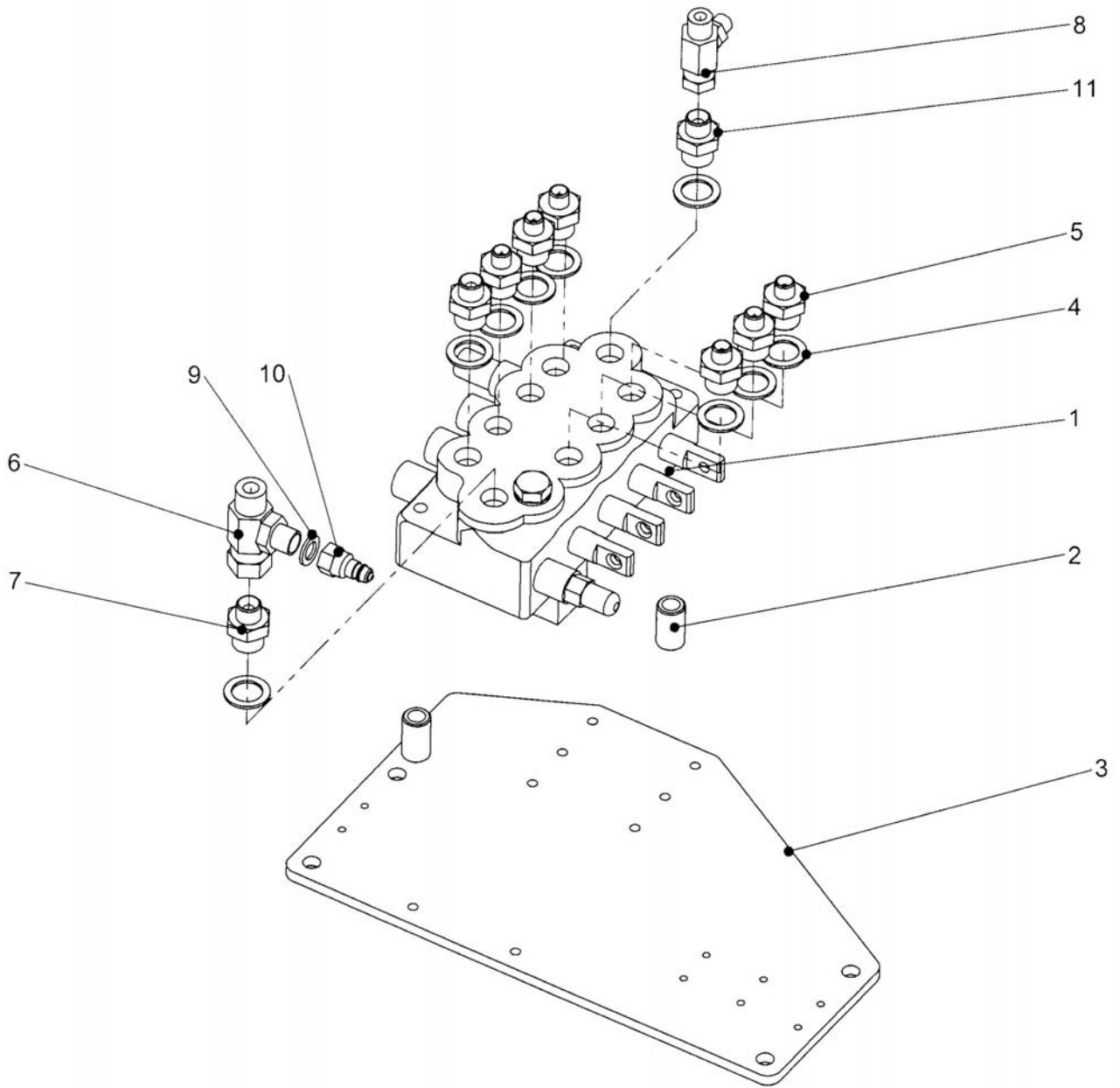

REF	PART NO	DESCRIPTION	QTY
77.359.01		CONTROL VALVE ASSY 4 SERV	
01	46924.02	VALVE 4 SERVICE CABLE	1
01	05.281.02	FLT WASHER 10MM PLATED	3
01	05.282.01	SPRING WASHER 8MM	3
01	05.292.02	BOLT M8 X 90MM PLATED	3
02	46924.31	SPACER 3/4" X 33MM	3
03	46924.32	VALVE MTG PLATE 8MM	1
03	9343032	M5 X 16 SKT.HD. CAPSCREW	6
04	05.290.05	BONDED SEAL 1/2"BSP	9
05	01.099.03	ADAPTOR 1/2BSP X 1/4BSP	7
06	04.056.25	ADAPTOR T FMM 1/2"X1/2"X1/4"	1
07	05.122.01	ADAPTOR 1/2" BSP X 1/2" BSP	1
08	04.056.16	ADAPTOR F/M/M 3/8X3/8X1/4 BSP	1
09	05.290.02	BONDED SEAL 1/4"BSP	1
10	05.146.12	Q/R COUPLING 1/4" BSP MALE	1
11	05.123.01	ADAPTOR 1/2" BSP X 3/8" BSP	1

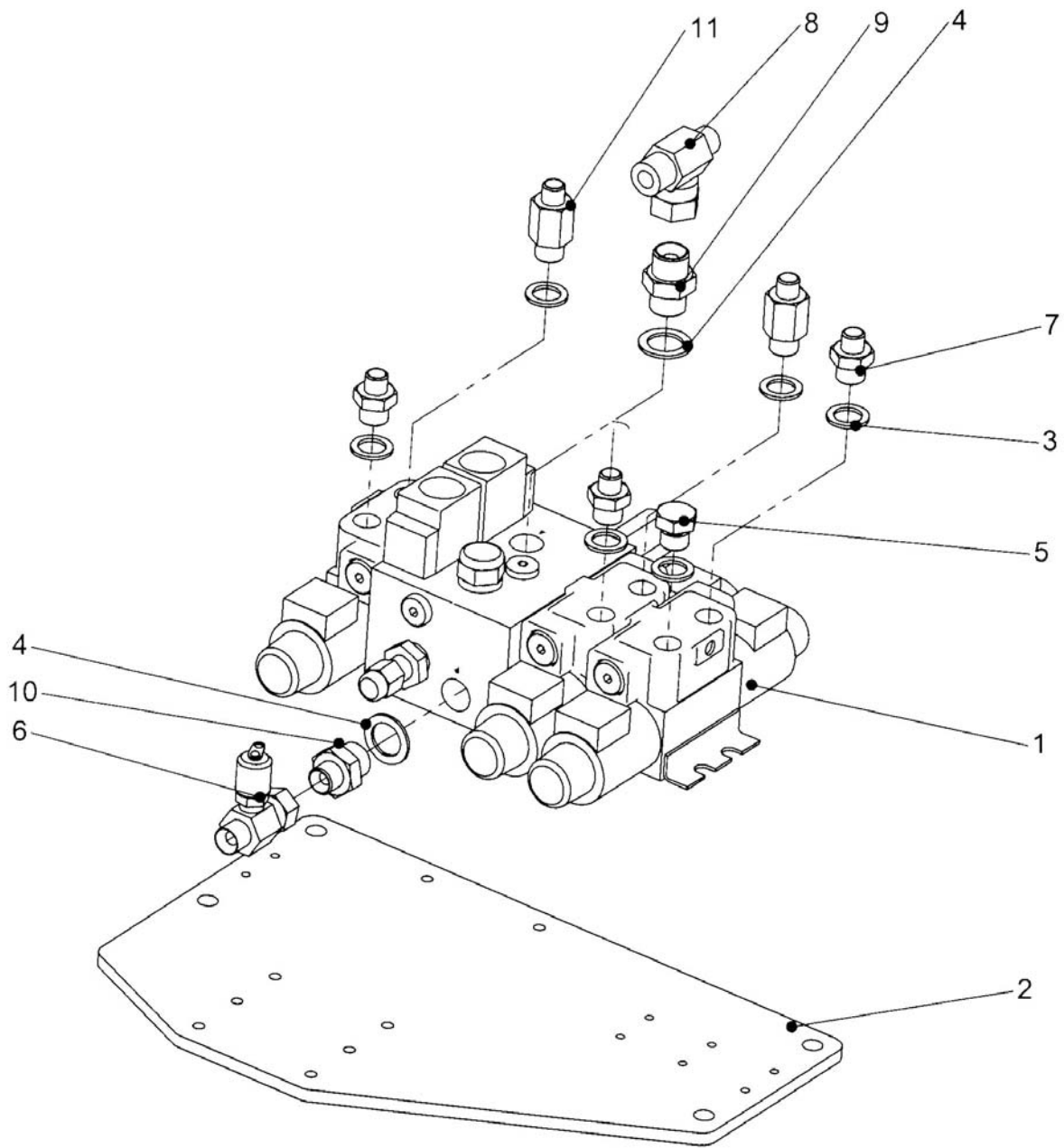



REF	PART NO	DESCRIPTION	QTY
<b>76.427.32</b>	<b>DMV CONTROL VALVE ASSEMBLY – 3 SERVICE</b>		
01*	46622.11	VALVE ASSY	1
01	05.281.10	FLAT WASHER 6MM PLATED	4
01	05.282.07	SPRING WASHER 6MM PLATED	4
01	05.839.05	SETSCREW M6 X 16MM PLATED	4
02	46924.32	PLATE - VALVE MOUNTING	1
03	05.290.04	BONDED SEAL 3/8"BSP	6
04	05.290.05	BONDED SEAL 1/2"BSP	2
05	05.433.01	PLUG 3/8"BSP PLATED	1
06	8131004	MF TEST UNION 3/8" BSP	1
07	01.099.01	ADAPTOR 3/8BSP X1/4BSP	4
08	04.056.49	ADAPTOR - TEE 1/2M-3/8M-1/2F	1
09	05.122.01	ADAPTOR 1/2" BSP X 1/2" BSP	1
10	05.123.01	ADAPTOR 1/2" BSP X 3/8" BSP	1
11	05.819.02	ADAPTOR 3/8"BSP MALE	2

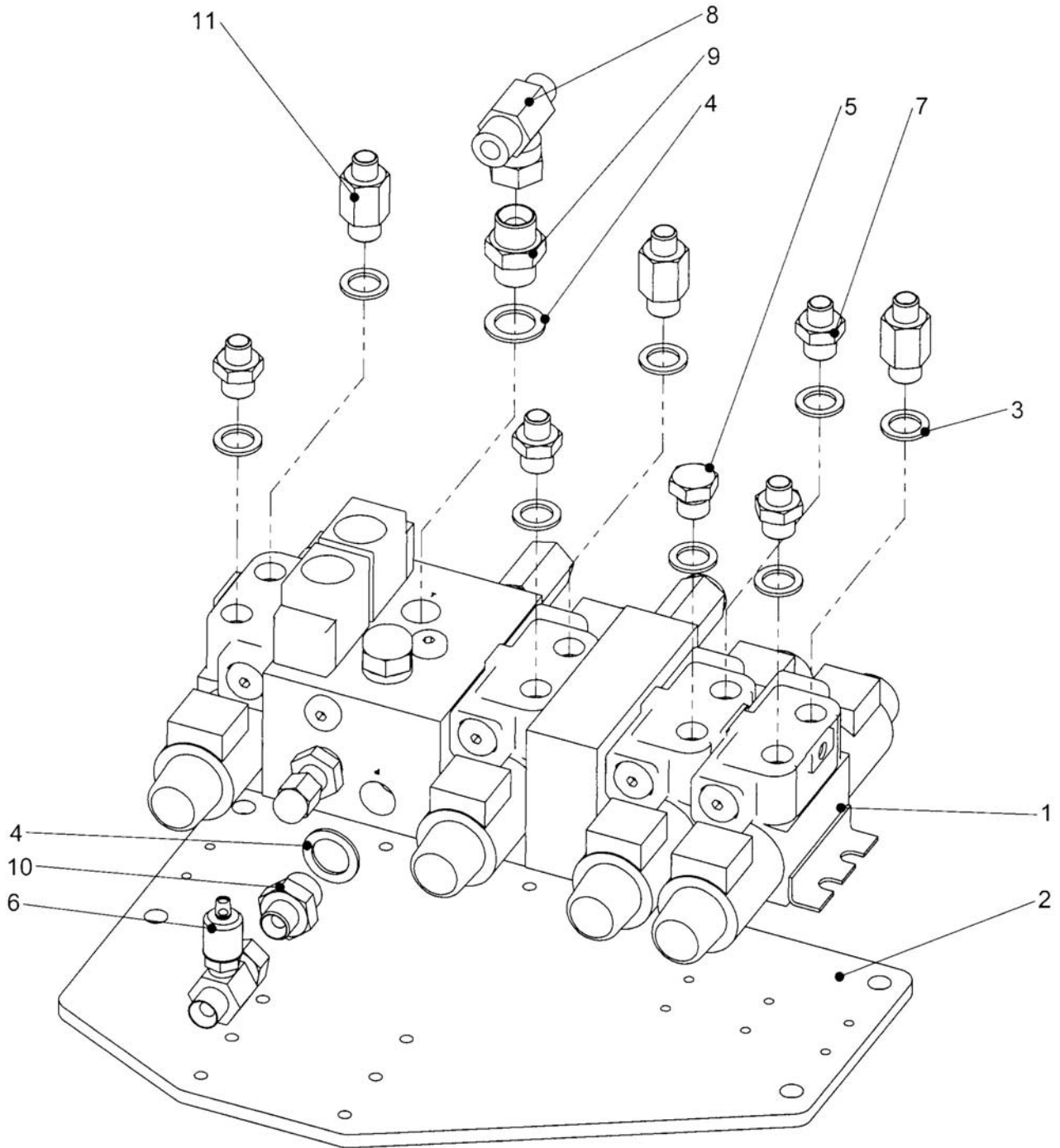

REF	PART NO	DESCRIPTION	QTY
<b>76.427.33</b>	<b>DMV CONTROL VALVE ASSEMBLY – 4 SERVICE</b>		
01*	46622.12	VALVE ASSY	1
01	05.281.10	FLAT WASHER 6MM PLATED	4
01	05.282.07	SPRING WASHER 6MM PLATED	4
01	05.839.05	SETSCREW M6 X 16MM PLATED	4
02	46924.32	PLATE - VALVE MOUNTING	1
03	05.290.04	BONDED SEAL 3/8"BSP	8
04	05.290.05	BONDED SEAL 1/2"BSP	2
05	05.433.01	PLUG 3/8"BSP PLATED	1
06	8131004	MF TEST UNION 3/8" BSP	1
07	01.099.01	ADAPTOR 3/8BSP X1/4BSP	4
08	04.056.49	ADAPTOR - TEE 1/2M-3/8M-1/2F	1
09	05.122.01	ADAPTOR 1/2" BSP X 1/2" BSP	1
10	05.123.01	ADAPTOR 1/2" BSP X 3/8" BSP	1
11	05.819.02	ADAPTOR 3/8"BSP MALE TO	3

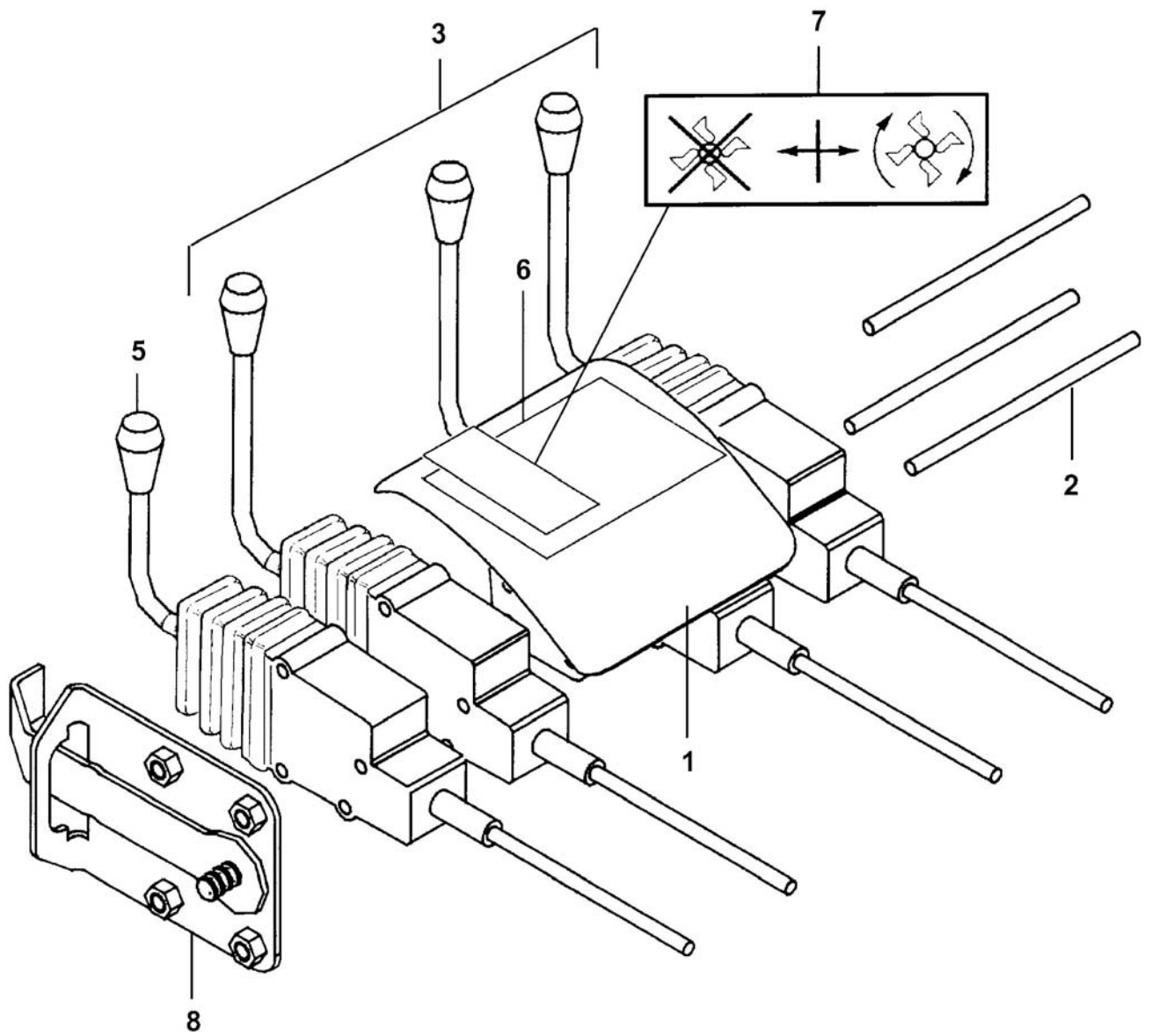

REF	PART NO	DESCRIPTION	QTY
<b>74.647.17 CABLE ASSY - 4 LEVER LH</b>			
01	42256.01	ARM REST - 4 LEVER	1
*02	04.282.01	STUD M8 X 196MM PLATED	3
02	05.281.01	FLAT WASHER 8MM PLATED	3
02	05.948.07	WING NUT M8 - PLATED	3
02	05.286.01	NUT M8	3
03	04.265.96	R.C.ASSY 3.0M LNG BLK KA10 FK	3
05	04.265.93	R.C.ASSY 3.0M SHT RED DIV FK	1
06	09.916.29	DECAL - LEVER OP. 4 LEVER LH	1

**74.647.09 CABLE ASSY - 4 LEVER LH**

01	42256.03	ARM REST - 5 LEVER	1
*02	04.282.01	STUD M8 X 196MM PLATED	3
02	05.281.01	FLAT WASHER 8MM PLATED	3
02	05.948.07	WING NUT M8 - PLATED	3
02	05.286.01	NUT M8	3
03	04.265.96	R.C.ASSY 3.0M LNG BLK KA10 FK	4
05	04.265.93	R.C.ASSY 3.0M SHT RED DIV FK	1
06	09.916.01	DECAL - LEVER OP. 5 LEVER LH	1

\*MAIN PART IN GROUP, RELATED PARTS HAVE SAME REFERENCE NUMBER

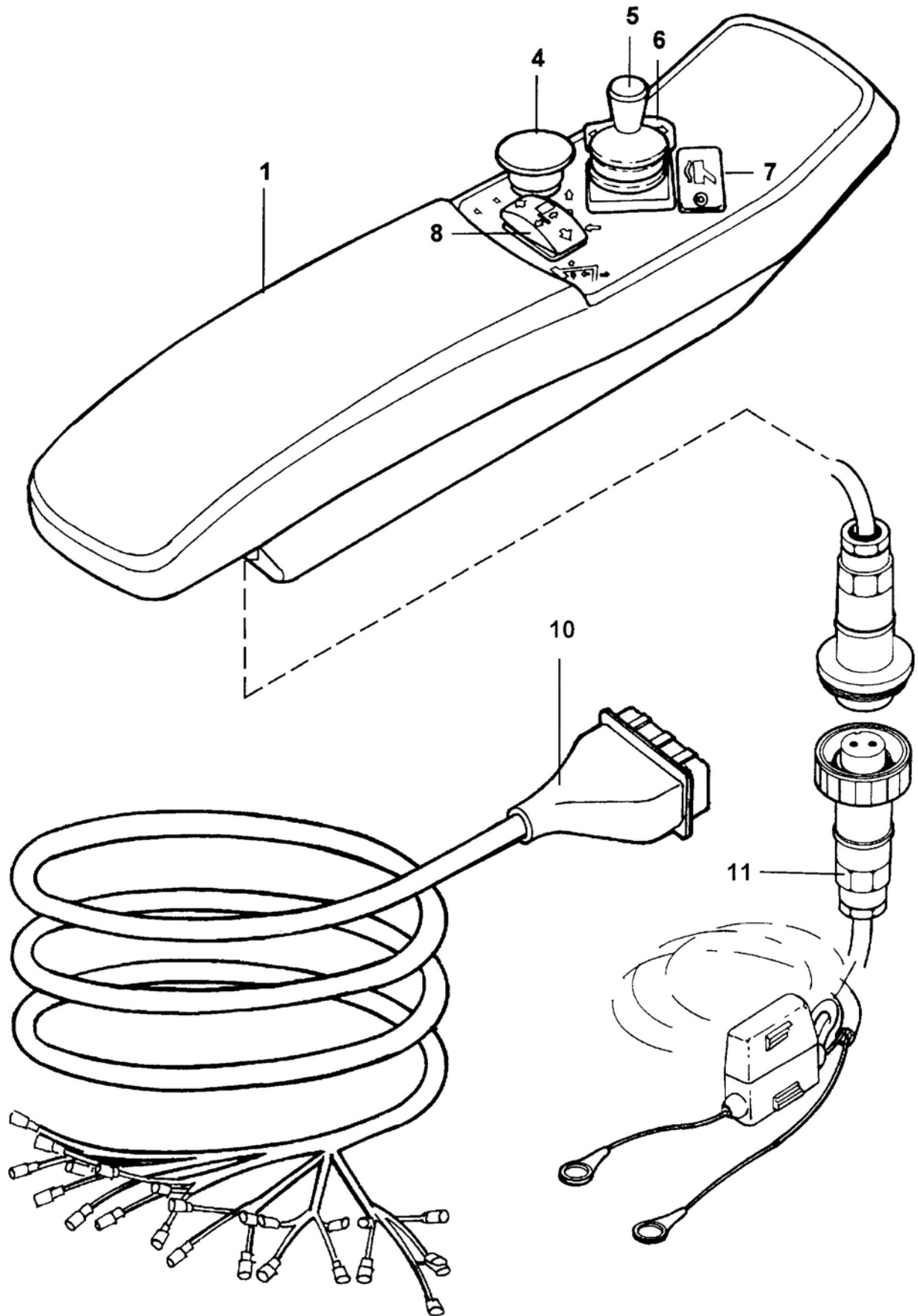

REF	PART NO	DESCRIPTION	QTY
76.426.03 EPPII 3SV +HF RCA ASY LH			
01	42226.11	CONTROL BOX 3 SERVICE LH	1
02	42226.96	DECAL SET EPPII LH	1
03	42226.84	MAIN PCB ASSY EPPII	0
04	41786.33	STOP SWITCH	0
05	41786.34	JOYSTICK ASSY	0
06	41786.35	SWITCH ASSY COWL	0
07	41786.38	SWITCH ASSY HEAD FLOAT	0
10	42197.11	WIRE LOOM	1
11	08.987.01	CABLE ASSY - 2 CORE X 5.5M HVY	1

## 76.426.41 EPPII 4SV +HF/AF RCA ASY LH/RH

01	42226.14	CONTROL BOX 4 SERVICE RH	1
02	42226.95	DECAL SET EPPII RH	0
03	42226.84	MAIN PCB ASSY EPPII	0
04	41786.33	STOP SWITCH	0
05	41786.34	JOYSTICK ASSY	0
06	41786.35	SWITCH ASSY COWL	0
07	41786.38	SWITCH ASSY HEAD FLOAT	0
08	41786.36	SWITCH ASSY SLEW	0
09	41786.43	SWITCH ASSY ARM FLOAT	0
10	42197.32	WIRE LOOM	1
11	08.987.01	CABLE ASSY - 2 CORE X 5.65M HVY	1

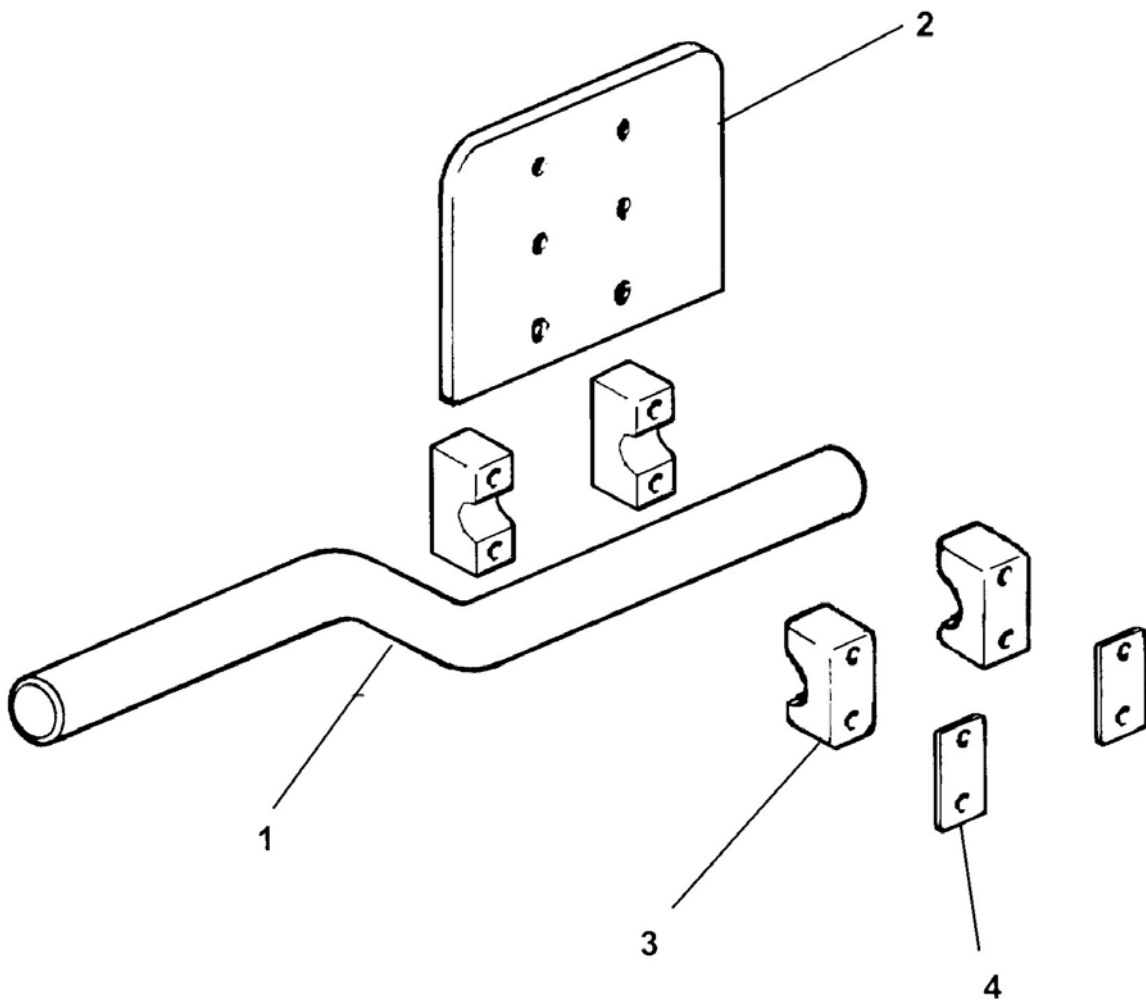



REF	PART NO	DESCRIPTION	QTY
<b>76.426.25 EPPIIM RCA CAB SIDE MNT</b>			
01	42312.02	BRACKET - MOUNTING	1
02	05.264.02	SETSCREW M8 X 25MM PLATED	2
02	05.281.01	FLAT WASHER 8MM PLATED	2
02	05.282.01	SPRING WASHER 8MM PLATED	2
02	05.948.07	WING NUT M8 - PLATED	2
02*	08.317.01	PLATE - CONTROL BOX	1
03	30.068.90	BOLT M6 X 55 MM 8.8 GRADE Z/P.	4
03	30.070.64	NUT NYLOC M6.Z/P.	4
03*	30.209.71	CLAMP SINGLE 1"	4
04	30.209.73	COVER PLATE	2
10	06.729.02	PLUG - PLASTIC 1"X10-12SWG	2

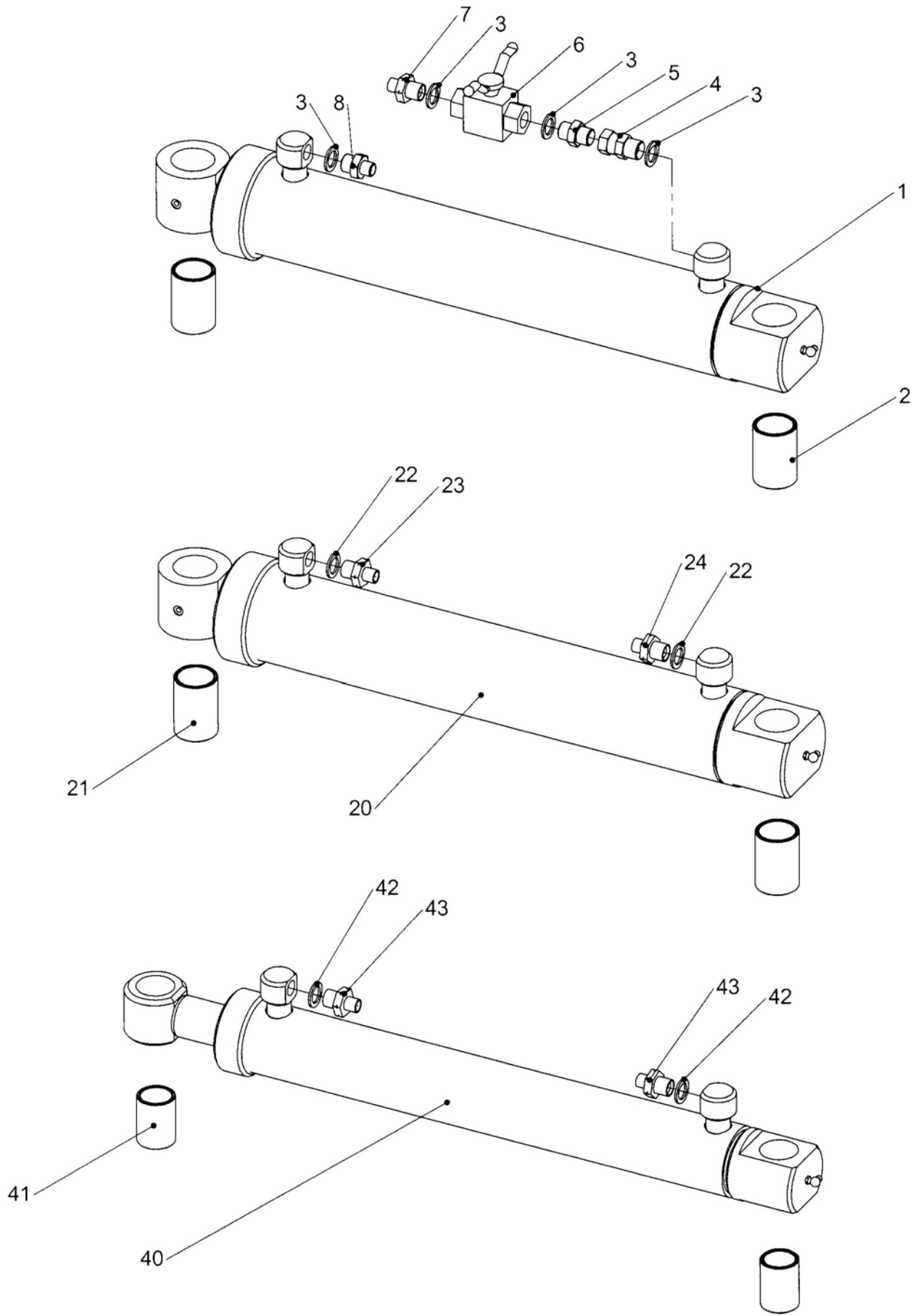

REF	PART NO	DESCRIPTION	QTY
<b>77.104.09 RAM ASSY FIRST CABLE PAR 8852</b>			
*01	46002.02	RAM ASSY D/A 80 BORE X 400 STK	1
01	05.953.01	GREASE NIPPLE M6	1
01	05.953.05	GREASE NIPPLE M6 X 90DEG	1
02	08.297.08	PLASTIC BUSH - 42 X 35 - 60	2
03	05.290.04	BONDED SEAL 3/8"BSP	4
04	02.714.01	ADAPTOR-SWIVEL ST 3/8BSP M/F	1
05	05.124.01	ADAPTOR 3/8" BSP X 3/8" BSP	1
06	08.200.01	VALVE - ISOLATING 3/8" BSP	1
07	46518.12	RESTRICTOR 3/8" X 1/4" - 1.70	1
08	01.099.01	ADAPTOR 3/8" X 1/4"	1
<b>77.114.04 RAM ASSY SECOND CABLE PAR 8852</b>			
*20	46002.02	RAM ASSY D/A 80 BORE X 400 STK	1
20	05.953.01	GREASE NIPPLE M6	1
20	05.953.05	GREASE NIPPLE M6 X 90DEG	1
21	08.297.08	PLASTIC BUSH - 42 X 35 - 60	2
22	05.290.04	BONDED SEAL 3/8"BSP	2
23	46518.12	RESTRICTOR 3/8" X 1/4" - 1.70	1
24	46518.08	RESTRICTOR 3/8" X 1/4" - 1.27	1
<b>77.113.02 RAM ASSY COWL 8852</b>			
*40	45990.01	RAM ASSY D/A 60 BORE X 430 STK	1
40	05.953.01	GREASE NIPPLE M6	1
40	05.953.05	GREASE NIPPLE M6 X 90DEG	1
41	08.297.14	PLASTIC BUSH37 X 30 - 50	2
42	05.290.04	BONDED SEAL 3/8"BSP	2
43	46518.08	RESTRICTOR 3/8" X 1/4"BSP 1.27	2

\*MAIN PART IN GROUP, RELATED PARTS HAVE SAME REFERENCE NUMBER

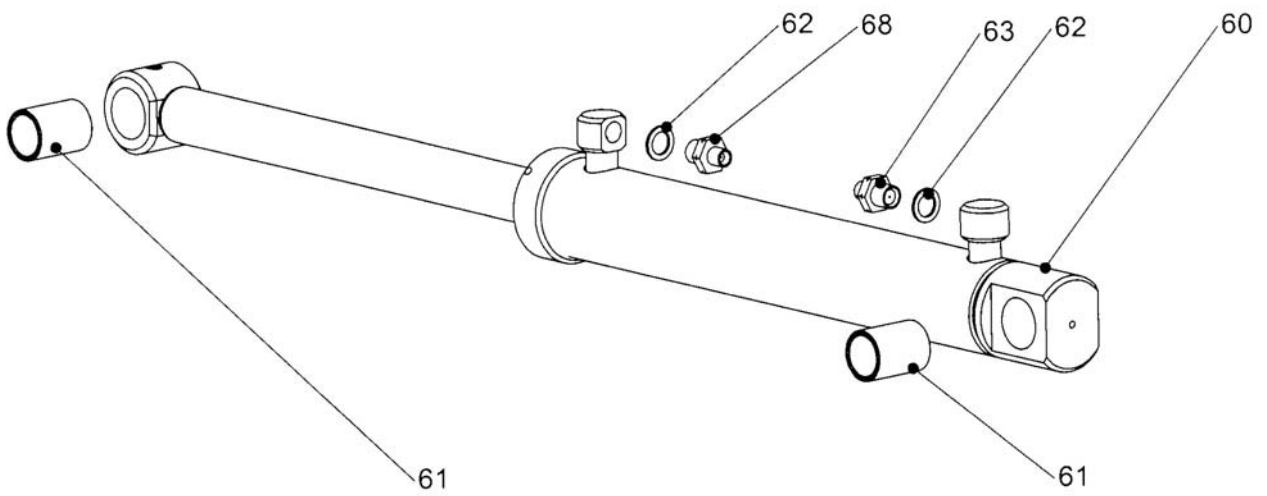
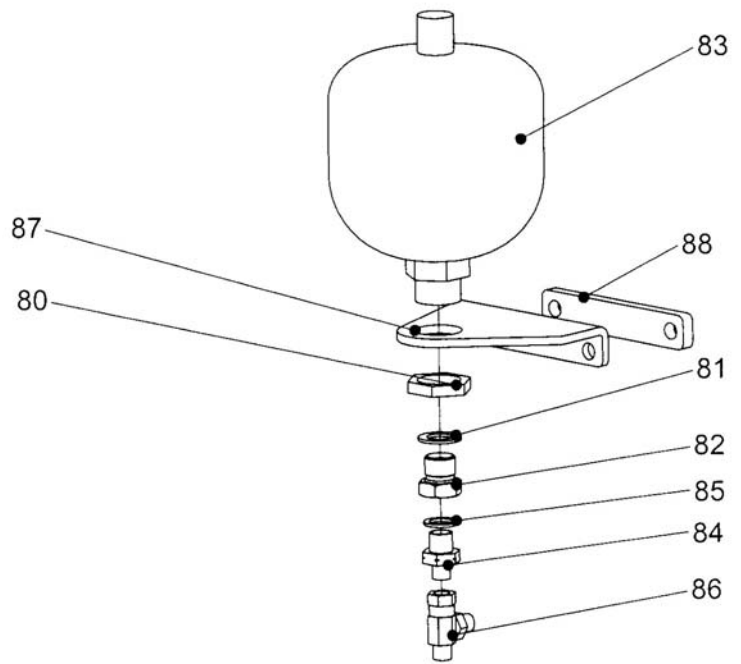

REF	PART NO	DESCRIPTION	QTY
77.217.01 SLEW RAM 9069			
60	05.953.01	GREASE NIPPLE M6	1
60	05.953.05	GREASE NIPPLE M6 X 90DEG	1
60*	45942.01	RAM ASSY D/A 60 BORE X 340 STK	1
61	08.297.14	PLASTIC BUSH37 X 30 - 50	2
62	05.290.04	BONDED SEAL 3/8"BSP	2
63	03.028.08	RESTRICTOR 3/8" X 1/4"BSP 1.27	1
68	03.028.14	RESTRICTOR 3/8" X 1/4"BSP 0.75	1
	10.001.24	HOSE 1/4"BSP STXST S.SEAL 1400	2
	10.002.10	HOSE 1/4"BSP STX90 S.SEAL 500	1
77.117.04 ACCUMULATOR - SLEW ASSY 8852			
80	8126035	M33 BULKHEAD NUT 'THIN'	1
81	0650322	BONDED SEAL	1
82	8581284	ADAPTOR M22 X 3/8"BSP MF	1
83	8126043	ACCUMULATOR 1.4LT - 90 BAR	1
84	46518.08	RESTRICTOR 3/8" X 1/4"BSP 1.27	1
85	05.290.04	BONDED SEAL 3/8"BSP	1
86	04.056.10	ADAPTOR - TEE 1/4"BSP F/M/M	1
87	47122.01	MOUNTING BRACKET	1
87	05.281.02	FLAT WASHER 10MM	4
87	05.287.02	SELF LOCKING NUT	2
87	05.292.17	BOLT M10 X 140MM	2
88	47124.01	STRAP	1

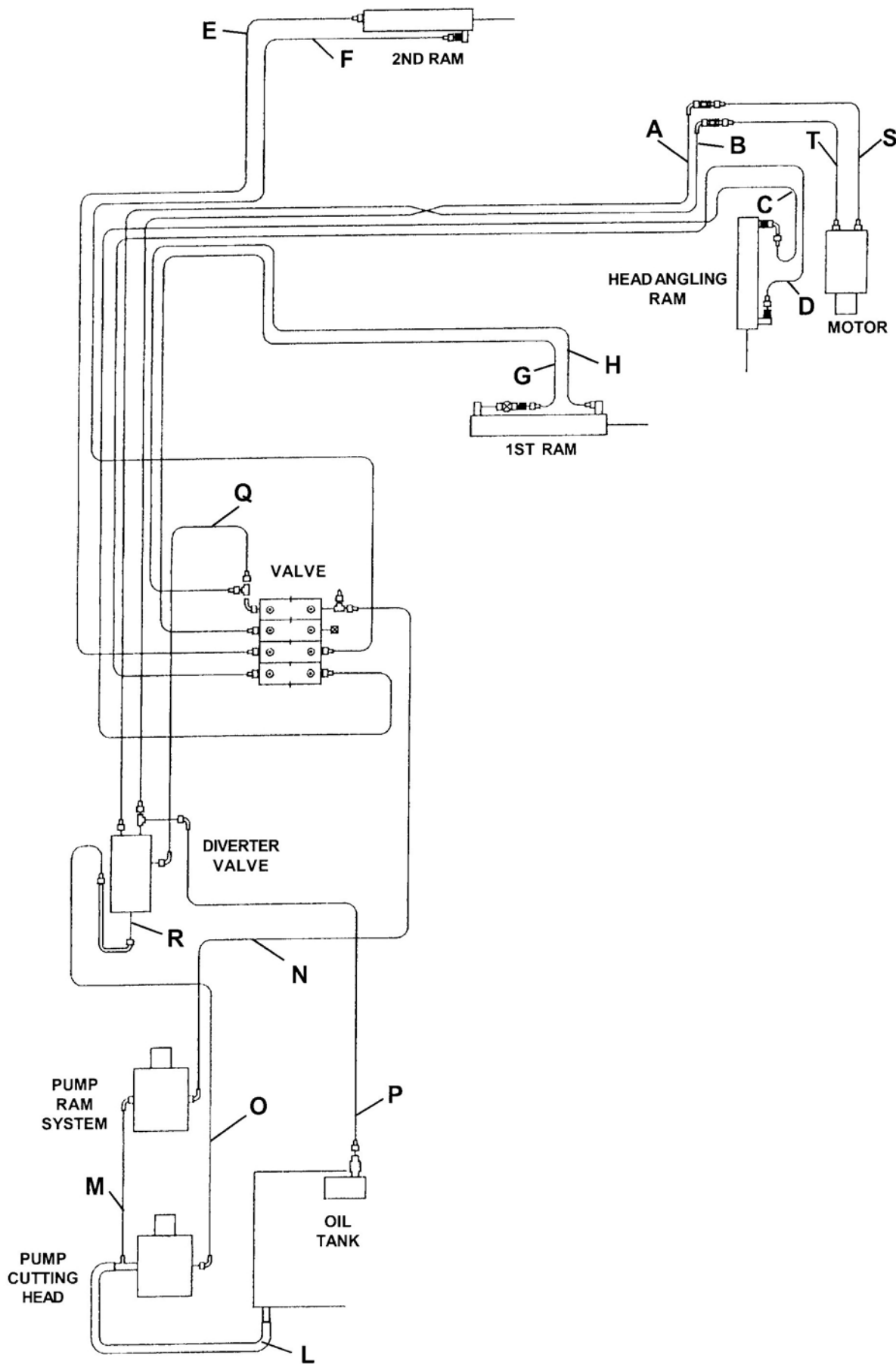

REF	PART NO	DESCRIPTION	QTY
<b>47058.01 HOSE KIT</b>			
A	10.012.70▲	HOSE 1" BSP ST X 90 X 6000	1
A	10.010.70▼	HOSE ¾" BSP ST X 90 X 6000	1
B	10.012.70▲	HOSE 1" BSP ST X 90 X 6000	1
B	10.010.70▼	HOSE ¾" BSP ST X 90 X 6000	1
C	10.002.63	HOSE ¼" BSP ST X 90 X 5300	1
D	10.002.63	HOSE ¼" BSP ST X 90 X 5300	1
E	10.002.36	HOSE ¼" BSP ST X 90 X 2600	1
F	10.002.36	HOSE ¼" BSP ST X 90 X 2600	1
G	10.002.24	HOSE ¼" BSP ST X 90 X1400	1
H	10.002.24	HOSE ¼" BSP ST X 90 X1400	1
L	10.024.16	HOSE 1 ½" SUCTION X 900	1
M	10.021.14	HOSE ¾" BSP SUCTION X 500	1
N	10.004.20	HOSE 3/8" BSP ST X 90 X 1000	1
O	10.009.12	HOSE ¾" BSP ST X ST X 600	1
P	10.012.11▲	HOSE 1" BSP ST X 90 X 550	1
P	10.010.14▼	HOSE ¾" BSP ST X 90 X 550	1
Q	10.006.21	HOSE ½" BSP ST X 90 X 1100	1
R	47080.01▶	STEEL/RUBBER HOSE ¾" BSP	1
R	47080.02◀	STEEL/RUBBER HOSE ¾" BSP	1
S	10.011.26▲	HOSE 1" BSP ST X ST X 1600	1
S	10.009.26▼	HOSE ¾" BSP ST X ST X 1600	1
T	10.011.26▲	HOSE 1" BSP ST X ST X 1600	1
T	10.009.26▼	HOSE ¾" BSP ST X ST X 1600	1

▲ 84 LTR MACHINES

▼ 70 LTR MACHINES

▶ LH MACHINES

◀ RH MACHINES

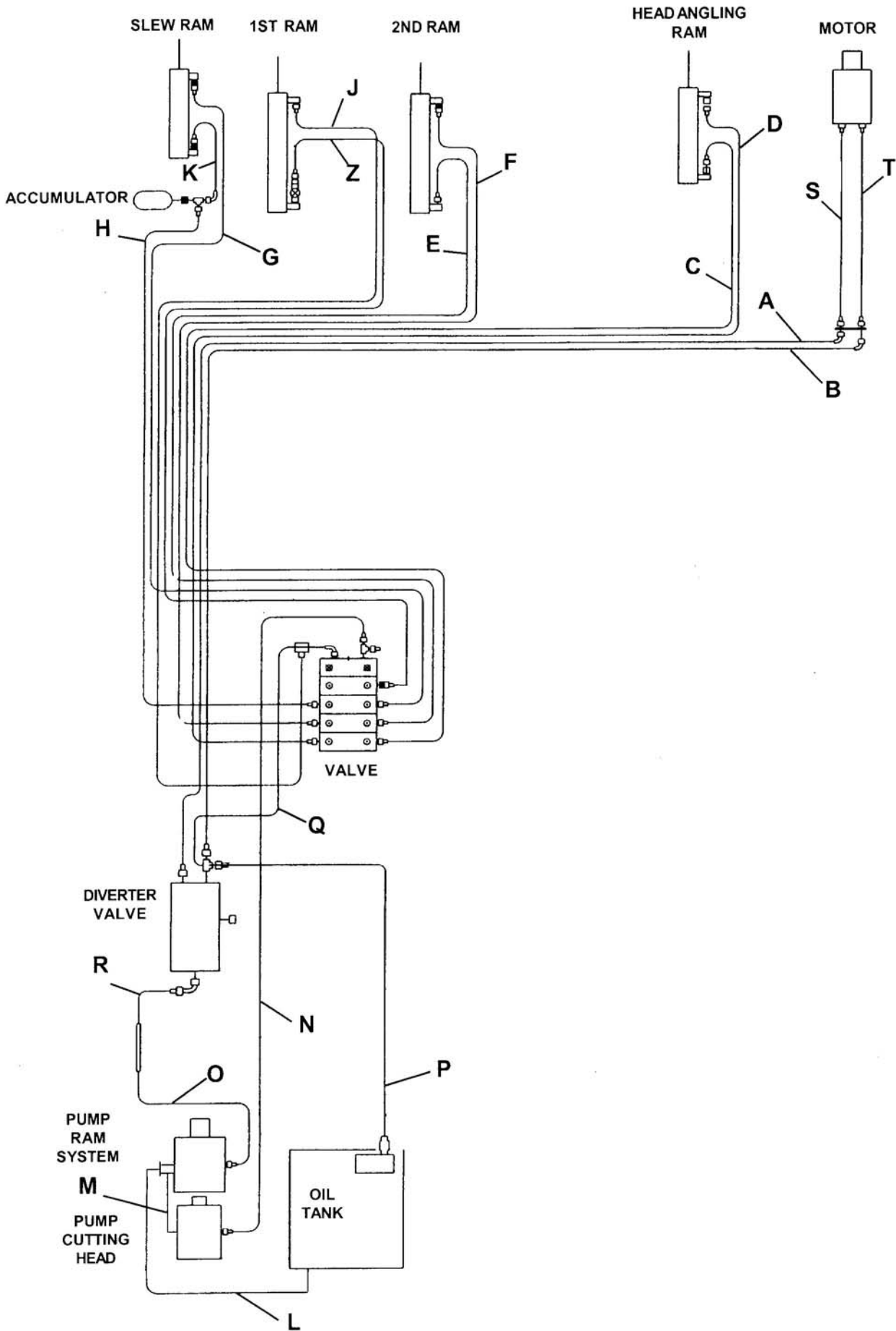



REF	PART NO	DESCRIPTION	QTY
<b>HOSES – POWER SLEW 84 LTR</b>			
A	10.025.73	HOSE 1" BSP ST X 135 X 6300	1
B	10.025.73	HOSE 1" BSP ST X 135 X 6200	1
C	10.002.63	HOSE 1/4" BSP ST X 90 X 5300	1
D	10.002.63	HOSE 1/4" BSP ST X 90 X 5300	1
E	10.002.36	HOSE 1/4" BSP ST X 90 X 2600	1
F	10.002.37	HOSE 1/4" BSP ST X 90 X 2700	1
G	10.002.25	HOSE 1/4" BSP ST X 90 X1500	1
H	10.002.25	HOSE 1/4" BSP ST X 90 X1500	1
J	10.002.24	HOSE 1/4" BSP ST X 90 X3500	1
K	10.002.10	HOSE 1/4" BSP ST X90 X 500	1
L	10.024.17▶	HOSE 1 1/2" SUCTION X 500	1
L	10.024.18◀	HOSE 1 1/2" SUCTION X 500	1
M	10.021.14	HOSE 3/4" BSP SUCTION X 500	1
N	10.004.20	HOSE 3/8" BSP ST X 90 X 1000	1
O	10.009.12	HOSE 3/4" BSP ST X ST X 600	1
P	10.012.11	HOSE 1" BSP ST X 90 X 550	1
Q	10.006.13	HOSE 1/2" BSP ST X 90 X 650	1
R	47080.01▶	STEEL/RUBBER HOSE 3/4" BSP	1
R	47080.02◀	STEEL/RUBBER HOSE 3/4" BSP	1
S	10.011.26	HOSE 1" BSP ST X ST X 1600	1
T	10.011.26	HOSE 1" BSP ST X ST X 1600	1
Z	10.002.24	HOSE 1/4" BSP ST X 90 X3500	1

▶ LH MACHINES

◀ RH MACHINES

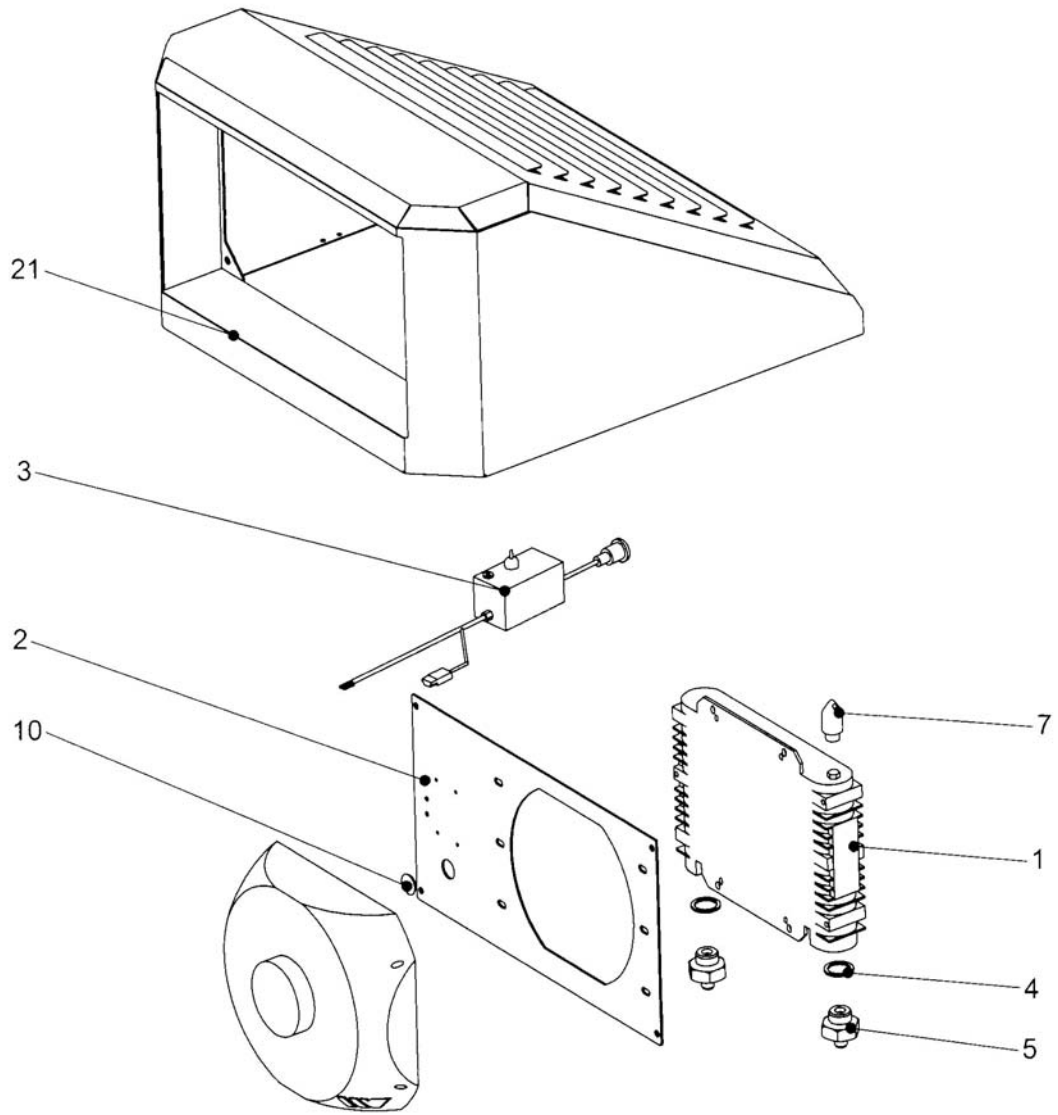

**77.146.12 OIL COOLER ASSY (From Machine Serial No. 3060S/05)**

01	47313.02	OIL COOLER	1
02	47379.01	MOUNTING PLATE	1
02	05.291.01	BOLT, M8 X 30	3
03	42162.07	RELAY BOX AND LOOM	1
03	05.282.07	SPRING WASHER 6MM	4
03	05.839.05	SET SCREW M6 X 16MM	4
04	05.290.07	BONDED SEAL 1" BSP	2
05	30.059.84	ADAPTOR 1" BSPM X ½" BSPM	2
06	10.006.20	HOSE ½" BSP ST X 90 1000 1 (Not Illustrated)	1
07	45324.02	THERMOSTAT	1
08	08.987.02	POWER CABLE ASSEMBLY(Not Illustrated)	1
09	46650.01	CABLE – OIL COOLER TO RELAY (Not Illustrated)	1
10	03.816.01	PLUG RUBBER - BLANKING	1

**77.410.02 VENTED TANK LID**

21	47320.04	VENTED TANK LID	1
21	30.216.54	RIVNUT M8	4

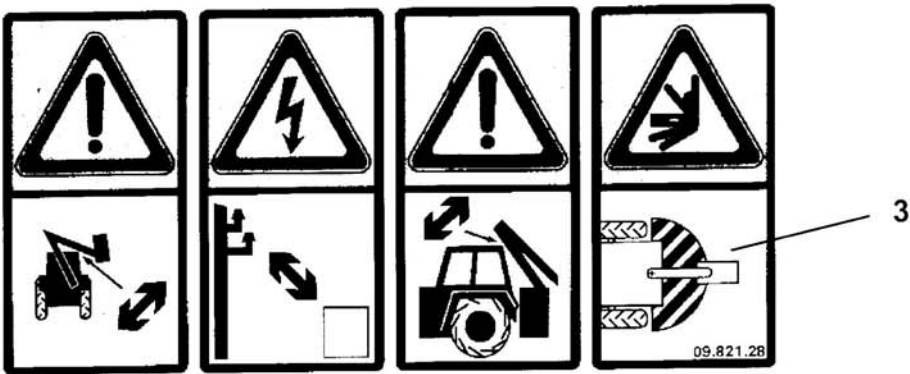
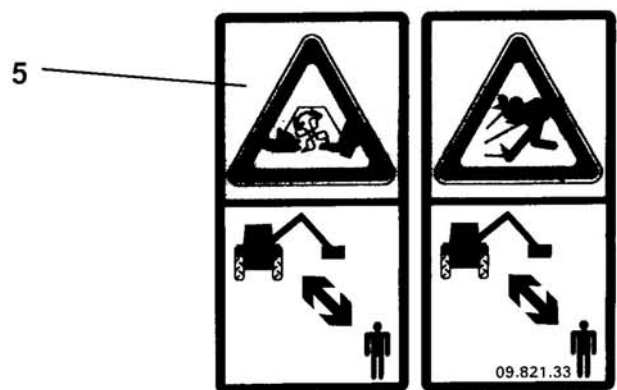

<b>REF</b>	<b>PART NO</b>	<b>DESCRIPTION</b>	<b>QTY</b>
<b>77.138.01 DECALS ENGINEERING 8852</b>			
01	08.632.01	DECAL - TRANSPORT	1
02	09.811.04	DECAL - MAX PTO SPEED 540 ACW	1
03	09.821.28	DECALS-EURO DECAL MINIATURISED	1
04	09.821.32	DECALS-EURO DECAL MINIATURISED	1
05	09.821.33	DECALS-EURO DECAL MINIATURISED	1
06	09.821.34	DECALS-EURO DECAL MINIATURISED	1
07	09.843.06	DECAL - LIFT POINT 1500 KG	1
08	09.845.01	DECAL - APPROVED OILS	1
09	09.846.02	DECAL - OIL FILTER CHANGE	1
<b>77.345.01 DECALS MARKETING - HARRIER</b>			
21	45645.01	DECAL - BOMFORD (72MM FONT)	1
22	45645.02	DECAL - BOMFORD (50MM FONT)	1
23	47071.01	DECAL - HARRIER	1